

# DESIGN OF REVETMENTS

K. W. Pilarczyk

Dutch Public Works Department (RWS), Hydraulic Engineering Division,  
P.O. Box 5044, 2600 GA Delft, The Netherlands; k.w.pilarczyk@dww.rws.minvenw.nl

## 1 INTRODUCTION

The use of revetments, such as riprap, blocks and block mats, various mattresses, and asphalt in civil engineering practice is very common. The granular filters, and more recently the geotextiles, are more or less standard components of the revetment structure (PIANC, 1987,1992).

Within the scope of the research on the stability of open slope revetments, much knowledge has been developed about the stability of placed (pitched) stone revetments under wave load (CUR/TAW, 1995) and stability of rock under wave and current load (CUR/CIRIA, 1991, CUR/RWS, 1995).

Until recently, no or unsatisfactory design tools were available for a number of other (open) types of revetment and for other stability aspects. This is why the design methodology for placed block revetments has recently been extended in applicability by means of a number of desk-studies for other (open) revetments:

- interlock systems and block mats;
- gabions;
- concrete mattresses;
- geosystems, such as sandbags and sand sausages;

and other stability aspects, such as: flow-load stability, soil-mechanical stability and residual strength.

This chapter, based partly on the paper by Klein Breteler et al., 1998, aims at giving a summary of the increased knowledge, especially that concerning the design tools that have been made available. The details behind it can be found in (Pilarczyk et al., 1998).

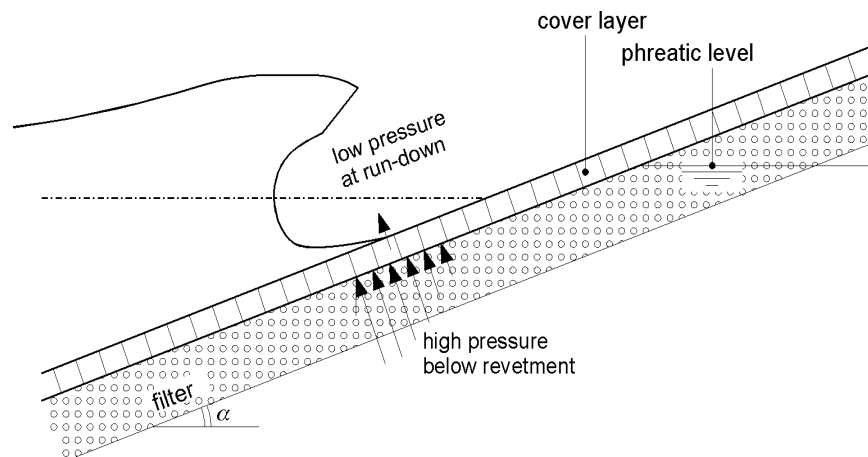

Figure 1 Pressure development in a revetment structure

## 2 THEORETICAL BACKGROUND OF WAVE LOADING

Wave attack on revetments will lead to a complex flow over and through the revetment structure (filter and cover layer). During wave run-up the resulting forces by the waves will be directed opposite to the gravity forces. Therefore the run-up is less hazardous than the wave run-down. Wave run-down will lead to two important mechanisms:

- The downward flowing water will exert a drag force on the cover layer and the decreasing freatic level will coincide with a downward flow gradient in the filter (or in a gabion). The first mechanism can be schematised by a free flow in the filter or gabion with a typical gradient equalling the slope angle. It may result in sliding.
- During maximum wave run-down there will be an incoming wave that a moment later will cause a wave impact. Just before impact there is a 'wall' of water giving a high pressure under the point of maximum run-down. Above the run-down point the surface of the revetment is almost dry and therefore there is a low pressure on the structure. The high pressure front will lead to an upward flow in the filter or a gabion. This flow will meet the downward flow in the run-down region. The result is an outward flow and uplift pressure near the point of maximum wave run-down (Figure 1).

The schematised situation can be quantified on the basis of the Laplace equation for linear flow:

$$\frac{\partial^2 \phi}{\partial y^2} + \frac{\partial^2 \phi}{\partial z^2} = 0 \quad (1)$$

with:  $\phi = \phi_b$  = potential head induced in the filter or a gabion (m)  
 $y$  = coordinate along the slope (m)  
 $z$  = coordinate perpendicular to the slope (m)

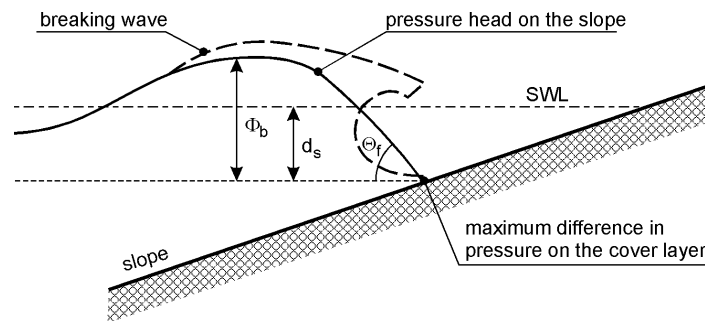

Figure 2 Schematization of pressure head on a slope

After complicated calculations the uplift pressure in the filter or a gabions can be derived. The uplift pressure is dependent on the steepness and height of the pressure front on the cover layer (which is dependent on the wave height, period and slope angle, see Figure 2), the thickness of the cover layer and the level of the phreatic line in the filter or a gabion. In case of riprap or gabions, it is not dependent on the permeability of the cover layer, if the permeability is much larger then the subsoil. For semi-permeable cover layers the equilibrium of uplift forces and gravity forces (defined by components of a revetment) leads to the following (approximate) design formula (Pilarczyk et al 1998):

$$\frac{H_{scr}}{\Delta D} = f \left( \frac{D}{\Lambda \xi_{op}} \right)^{0.67} \quad \text{with} \quad \Lambda = \sqrt{\frac{b D k}{k'}} \quad (2a)$$

$$\text{or} \quad \frac{H_{scr}}{\Delta D} = f \left( \frac{D k'}{b k} \right)^{0.33} \xi_{op}^{-0.67} \quad (2b)$$

$$\text{or} \quad \frac{H_{scr}}{\Delta D} = F \xi_{op}^{-0.67} \quad (2c)$$

where  $H_{scr}$  = significant wave height at which blocks will be lifted out [m];  $\xi_{op} = \tan \alpha \sqrt{(H_s / (1.56 T_p^2))}$  = breaker parameter;  $T_p$  = wave period at the peak of the spectrum [s];  $\Lambda$  = leakage length [m],  $\Delta = (\rho_s - \rho) / \rho =$

relative volumetric mass of cover layer;  $b$  = thickness of a sublayer [m],  $D$  = thickness of a top (cover) layer [m],  $k$  = permeability of a sublayer [m/s],  $k'$  = permeability of a top layer [m/s],  $f$  = stability coefficient, mainly dependent on structure type,  $\tan\alpha$  and friction;  $F$  = total (black-box) stability factor.

The leakage length ( $\Lambda$ ) and stability coefficient ( $F$ ) are explained more in detail in the next sections.

### 3 STRUCTURAL RESPONSE

#### 3.1 Wave-load approach

There are two practical design methods available: the black-box model and the analytical model. In both cases, the final form of the design method can be presented as a critical relation of the load compared to strength, depending on the type of wave attack:

$$\left( \frac{H_s}{\Delta D} \right)_{cr} = \text{function of } \xi_{op} \quad (3a)$$

For semi-permeable cover layers, the basic form of this relation is:

$$\left( \frac{H_s}{\Delta D} \right)_{cr} = \frac{F}{\xi_{op}^{2/3}} \quad \text{with maximum } \left( \frac{H_s}{\Delta D} \right)_{cr} = 8.0 \quad \text{and } \text{ctg}\alpha \geq 2 \quad (3b)$$

or, in more general form (also applicable for riprap and  $\text{ctg}\alpha \geq 1.5$ ), as defined by Pilarczyk (1990, 1998):

$$\left( \frac{H_s}{\Delta D} \right)_{cr} = \frac{F \cos \alpha}{\xi_{op}^b} \quad (3c)$$

In which:  $F$  = revetment (stability) factor,  $H_s$  = (local) significant wave height (m),  $\Delta$  = relative density,  $D$  = thickness of the top layer (m),  $\xi_{op}$  = breaker parameter (-), and  $b$  = exponent;  $0.5 \leq b \leq 1.0$ .

The approximate values of stability factor  $F$  are:  $F = 2.25$  for riprap,  $F = 2.5$  for pitched stone of irregular shape,  $F = 3.0$  to  $3.5$  for pitched basalt,  $F = 4.0$  for geomattresses,  $3.5 \leq F \leq 5.5$  for block revetments (4.5 as an average/usual value),  $4.0 \leq F \leq 6.0$  for block mats (higher value for cabled systems),  $6.0 \leq F \leq 8.0$  for gabions, and  $6.0 \leq F \leq 10$  for (asphalt or concrete) slabs.

Exponent  $b$  refers to the type of wave-slope interaction and its value is influenced by the roughness and the porosity of a revetment. The following values of exponent  $b$  are recommended:  $b = 0.5$  for permeable cover layers (i.e., riprap, gabions, pattern grouted riprap, very open block mats),  $b = 2/3$  for semi-permeable cover layers (i.e., pitched stone and placed blocks, block mats, concrete- or sand-filled geomattresses, and  $b = 1.0$  for slabs.

The relative density is defined as follows:

$$\Delta = \frac{\rho_s - \rho_w}{\rho_w} \quad (4a)$$

with:  $\rho_s$  = density of the protection material and  $\rho_w$  = density of water ( $\text{kg/m}^3$ ). For porous top layers, such as sand mattresses and gabions, the relative density of the top layer must be determined, including the water-filled pores:

$$\Delta_t = (1 - n) \cdot \Delta \quad (4b)$$

In which:  $\Delta_t$  = relative density including pores and  $n$  = porosity of the top layer material.

D and  $\Delta$  are defined for specific systems such as:

- for rock:  $D = D_n = (M_{50}/\rho_s)^{1/3}$  (= nominal diameter) and  $\Delta_t = \Delta = (\rho_s - \rho_w)/\rho_w$
- for blocks:  $D =$  thickness of block and  $\Delta_t = \Delta$
- for mattresses:  $D = d =$  average thickness of mattress and  $\Delta_t = (1-n)\Delta$ , where  $n =$  bulk porosity of fill material and  $\Delta =$  relative density of fill material. For common quarry stone  $(1-n)\Delta \sim 1$ .

The breaker parameter is defined as follows:

$$\xi_{op} = \frac{\tan \alpha}{\sqrt{H_s / L_{op}}} \quad (5)$$

The wave steepness  $S_{op}$  is defined as:

$$S_{op} = \frac{H_s}{L_o} = \frac{2\pi H_s}{g T^2} \quad (6a)$$

In which:  $L_{op} = \frac{g}{2\pi} T_p^2 \quad (6b)$

with:  $\alpha =$  slope angle ( $^\circ$ ),  $L_{op} =$  deep-water wavelength at the peak period (m), and  $T_p =$  wave period at the peak of the spectrum (s).

The advantage of this black-box design formula is its simplicity. The disadvantage, however, is that the value of  $F$  is known only very roughly for many types of structures.

The analytical model is based on the theory for placed stone revetments on a granular filter (pitched blocks). In this calculation model, a large number of physical aspects are taken into account. In short, in the analytical model nearly all physical parameters that are relevant to the stability have been incorporated in the "leakage length":  $\Lambda = \sqrt{(bDk/k')}$ . The final result of the analytical model may, for that matter, again be presented as a relation such as Eqs. 2c or 3c where  $F = f(\Lambda)$ .

With a system without a filter layer (directly on sand or clay and geotextile) not the permeability of the filter layer, but the permeability of the subsoil (eventually with gullies/surface channels) is filled in. For the thickness of the filter layer it is examined to which depth changes at the surface affect the subsoil. One can fill in 0.5 m for sand and 0.05 m for clay. The values for  $D$  and  $\Delta$  depend on the type of revetment.

In the case of a geotextile situated directly under the cover layer, the permeability of the cover layer decreases drastically. Since the geotextile is pressed against the cover layer by the outflowing water, it should be treated as a part of the cover layer. The water flow through the cover layer is concentrated at the joints between the blocks, reaching very high flow velocities and resulting in a large pressure head over the geotextile. The presence of a geotextile may reduce  $k'$  by a factor 10 or more

To be able to apply the design method for placed stone revetments under wave load to other systems, the following items may be adapted:

- the revetment parameter  $F$ ;
- the (representative) strength parameters  $\Delta$  and  $D$ ;
- the design wave height  $H_s$ ;
- the (representative) leakage length  $\Lambda$ ;
- the increase factor  $\Gamma$  (friction/interlocking between blocks) on the strength.

Only suchlike adaptations are presented in this summarising review. The basic formulas of the analytical model are not repeated here. For these, reader is referred to (CUR/TAW 1995).

The wave attack on a slope can be roughly transformed into the maximum velocity component on a slope during run-up and run-down,  $U_{max}$ , by using the following formula:

$$U_{max} = p \sqrt{g H_s \xi_{op}} \quad (7)$$

(for irregular waves and smooth slopes:  $1 < p < 1.5$ )

### 3.2 Flow-load stability

There are two possible approaches for determining the stability of revetment material under flow attack. The most suitable approach depends on the type of load:

- flow velocity: 'horizontal' flow, flow parallel to dike;
- discharge: downward flow at slopes steeper than 1:10, overflow without waves; stable inner slope.

When the flow velocity is known, or can be calculated reasonably accurately, Pilarczyk's relation (Pilarczyk, 1990, 1999, Pilarczyk et al. 1998) is applicable:

$$\Delta D = 0.035 \frac{\Phi}{\Psi} \frac{K_T K_h}{K_s} \frac{u_{cr}^2}{2g} \quad (8)$$

in which:  $\Delta$  = relative density,  $D$  = characteristic thickness (m): for riprap  $D = D_n$  = nominal diameter as defined previously,  $g$  = acceleration of gravity ( $g=9.81 \text{ m/s}^2$ ),  $u_{cr}$  = critical vertically-averaged flow velocity (m/s),  $\Phi$  = stability parameter,  $\Psi$  = critical Shields parameter,  $K_T$  = turbulence factor,  $K_h$  = depth parameter, and  $K_s$  = slope parameter.

These parameters are explained below.

#### Stability parameter $\Phi$ :

The stability parameter  $\Phi$  depends on the application. Some guide values are:

Revetment type	Continuous toplayer	Edges and transitions
Riprap and placed blocks	1.0	1.5
Block mats, gabions, washed-in blocks, geobags, and geomattresses	0.5 to 0.75	0.75 to 1.0

#### Shields parameter $\Psi$ :

With the critical Shields parameter  $\Psi$  the type of material can be taken into account:

- riprap, small bags  $\Psi \approx 0.035$
- placed blocks, geobags  $\Psi \approx 0.05$
- blockmats  $\Psi \approx 0.07$
- gabions  $\Psi \approx 0.07$
- geomattresses  $\Psi \approx 0.07$

#### Turbulence factor $K_T$ :

The degree of turbulence can be taken into account with the turbulence factor  $K_T$ . Some guide values for  $K_T$  are:

- Normal turbulence:
  - abutment walls of rivers:  $K_T \approx 1.0$
- Increased turbulence:
  - river bends:  $K_T \approx 1.5$
  - downstream of stilling basins:  $K_T \approx 1.5$
- Heavy turbulence
  - hydraulic jumps:  $K_T \approx 2.0$
  - strong local disturbances:  $K_T \approx 2.0$
  - sharp bends:  $K_T \approx 2.0$  (to 2.5)
- Load due to water (screw) jet:  $K_T \approx 3.0$  (to 4.0)

#### Depth parameter $K_h$ :

With the depth parameter  $K_h$ , the water depth is taken into account, which is necessary to translate the depth-

averaged flow velocity into the flow velocity just above the revetment. The depth parameter also depends on the development of the flow profile and the roughness of the revetment.

The following formulas are recommended:

$$\text{fully developed velocity profile: } K_h = \frac{2}{\left(\log\left(\frac{12h}{k_s}\right)\right)^2} \quad (9a)$$

$$\text{non-developed profile: } K_h = \left(\frac{h}{k_s}\right)^{-0.2} \quad (9b)$$

$$\text{very rough flow (} h/k_s < 5 \text{): } K_h = 1.0 \quad (9c)$$

In which:  $h$  = water depth (m) and  $k_s$  = equivalent roughness according to Nikuradse (m).

In the case of dimensioning the revetment on a slope, the water level at the toe of the slope must be used for  $h$ . The equivalent roughness according to Nikuradse depends on the type of revetment/geosystem. For riprap,  $k_s$  is equal usually to one or twice the nominal diameter of the stones, for bags it is approximately equal to the thickness ( $d$ ), for mattresses it depends of the type of mattress:  $k_s$  of about 0.05 m for smooth types and about the height of the rib for articulating mats.

*Slope parameter  $K_s$ :*

The stability of revetment elements also depends on the slope gradient under which the revetment is applied, in relation to the angle of internal friction of the revetment. This effect on the stability is taken into account with the slope parameter  $K_s$ , which is defined as follows:

$$K_s = \sqrt{1 - \left(\frac{\sin \alpha}{\sin \theta}\right)^2} = \cos \alpha \sqrt{1 - \left(\frac{\tan \alpha}{\tan \theta}\right)^2} \quad (10a)$$

or

$$K_s = \cos \alpha_b \quad (10b)$$

with:  $\theta$  = angle of internal friction of the revetment material,  $\alpha$  = transversal slope of the bank ( $^\circ$ ), and  $\alpha_b$  = slope angle of river bottom (parallel along flow direction) ( $^\circ$ ).

The following values of  $\theta$  can be assumed as a first approximation:  $40^\circ$  for riprap,  $30^\circ$  to  $40^\circ$  for sand-filled systems, and  $90^\circ$  for stiff and anchored mortar-filled mattresses and (cabled) blockmats ( $K_s = \cos \alpha$ ). However, for flexible non-anchored mattresses and block mats (units without contact with the neighbouring units) this value is much lower, usually about 3/4 of the friction angle of the sublayer. In case of geotextile mattress and block mats connected to geotextile lying on a geotextile filter,  $\theta$  is about  $15^\circ$  to  $20^\circ$ .

The advantage of this general design formula of Pilarczyk is that it can be applied in numerous situations. The disadvantage is that the scatter in results, as a result of the large margin in parameters, can be rather wide.

With a downward flow along a steep slope it is difficult to determine or predict the flow velocity, because the flow is very irregular. In such case formulas based on the discharge are developed (Pilarczyk et al 1998).

### 3.3 Soil-mechanical stability

The water motion on a revetment structure can also affect the subsoil, especially when this consists of sand.

Geotechnical stability is dependent on the permeability and stiffness of the grain skeleton and the compressibility of the pore water (the mixture of water and air in the pores of the grain skeleton). Wave pressures on the top layer are passed on delayed and damped to the subsoil under the revetment structure and to deeper layers (as seen perpendicular to the slope) of the subsoil. This phenomenon takes place over a larger distance or depth as the grain skeleton and the pore water are stiffer. If the subsoil is soft or the pore water more compressible (because of the presence of small air bubbles) the compressibility of the system increases and large damping of the water pressures over a short distance may occur. Because of this, alternately water under-tension and over-tension may develop in the subsoil and corresponding to this an increasing and decreasing grain pressure. It can lead to sliding or slip circle failure, see Figure 3.

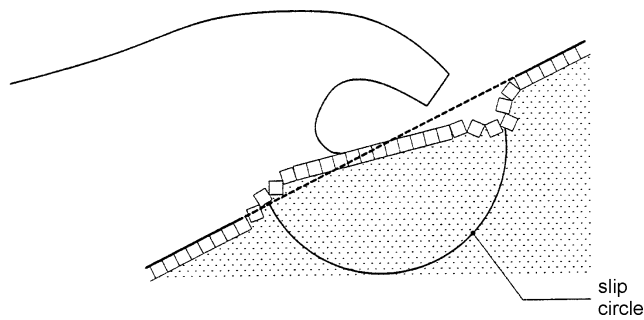

Figure 3 Schematised development of S-profile and possible local sliding in sand

The design method with regard to geotechnical instability is presented in the form of design diagrams. An example is given in Figure 4 (more diagrams and details: see Pilarczyk et al, 1998). The maximum wave height is a function of the sum of the cover layer weight ( $\Delta D$ ) and filter thickness ( $b_f$ ).

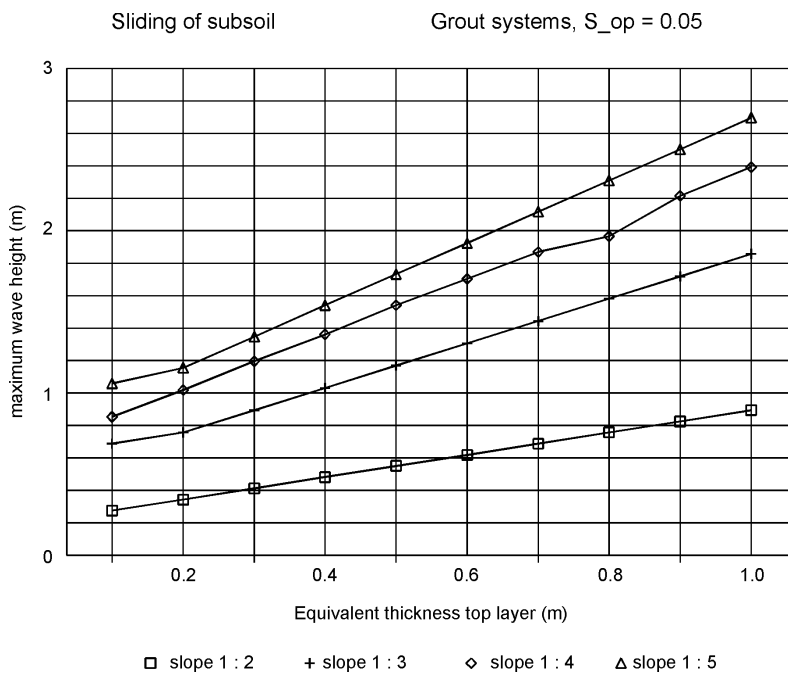

Figure 4 Geotechnical stability; design diagram for mattresses and  $H_s/L_{op} = 0.05$

### 3.4 Filters

Granular and/or geotextile filters can protect structures subjected to soil erosion when used in conjunction with revetment armour such as riprap, blocks and block mats, gabions and mattresses, asphalt or concrete slabs, or any other conventional armour material used for erosion control (PIANC, 1987, 1992).

However, there is still a misunderstanding about the function of geotextiles in the total design of these structures, especially in comparison with the granular filters. In this Section the general principles of designing revetments incorporating granular or geotextiles are reviewed. Attention is paid to the replacing of a granular filter by a geotextile, which may often lead to geotechnical instability. Furthermore it appears that a thicker granular filter gives a larger geotechnical stability, but a lower cover layer stability (uplift of blocks). The conclusion is therefore that the wave loads must be distributed (balanced) adequately over the sand (shear stress) and the cover layer (uplift pressure). Too much emphasis on one failure mechanism can lead to another mechanism.

Filters have two functions: erosion prevention and drainage. Traditional design criteria for filters are that they should be "geometrically tight" and that the filter permeability should be larger than the base (soil) permeability. However, it results in a large number of layers which are often unnecessary, uneconomical and difficult to realize. In several cases a more economical filter design can be realized

using the concept of "geometrically open filters" (e.g. when the hydraulic loads/gradients are too small to initiate erosion). Recently, some criteria for "geometrically open" filters including geotextiles were developed (and are still under further development). However, the application of these criteria requires the knowledge/prediction of the hydraulic loads.

In the cases when the erosion exceeds an acceptable level, a filter construction is a proper measure for solving this problem. In revetment structures geotextiles are mostly used to protect the subsoil from washing away by the hydraulic loads, such as waves and currents. Here the geotextile replaces a granular filter. Unfortunately, the mere replacing of a granular filter by a geotextile can endanger the stability of other components in the bank protection structure. The present section shows that designing a structure is more than just a proper choice of geotextile.

Filter structures can be realized by using granular materials (i.e. crushed stone), bonded materials (i.e. sand asphalt, sand cement), and geotextiles, or a combination of these materials. Typical filter compositions are shown in Figure 5. The choice between the granular filter, a bonded filter or geotextile depends on a number of factors. In general, a geotextile is applied because of easier placement and relatively lower cost. For example, the placement of granular filter underwater is usually a serious problem; the quality control is very difficult, especially when placement of thin layers is required.

When designing with geotextiles in filtration applications, the basic concepts are essentially the same as when designing with granular filters. The geotextile must allow the free passage of water (permeability function) whilst preventing the erosion and migration of soil particles into the armour or drainage system (retention function).

In principle, the geotextile must always remain more permeable than the base soil and must have pore sizes small enough to prevent the migration of the larger particles of the base soil. Moreover, concerning the permeability, not only the opening size but also the number of openings per unit area (Percent Open Area) is of importance (Pilarczyk, 1999).

It has to be stressed that geotextiles cannot always replace the granular filter completely. A granular layer can often be needed to reduce (damp) the hydraulic loadings (internal gradients) to an acceptable level at the soil interface. After that, a geotextile can be applied to fulfill the filtration function.

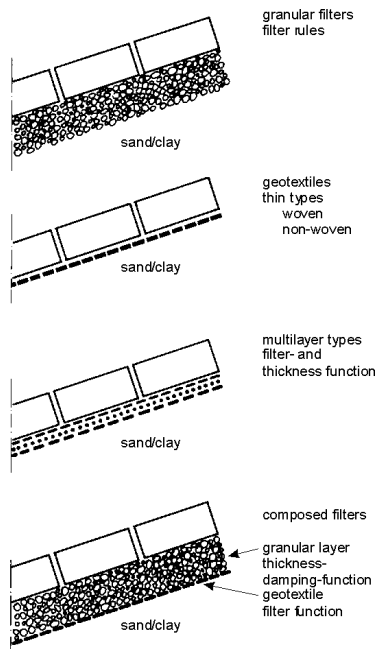

Figure 5 Examples of filters

In respect to the filters for erosion control (granular or geotextile) the distinction can be made between:

- \* geometrically tight filters,
- \* geometrically open filters, and
- \* transport filters (when a limited settlement is allowed).

Only geometrically tight filters are discussed. For other type of filters reader is referred to (Pilarczyk, 1999)



### 3.4.1 Design criteria for geometrically tight granular filters

In this case there will be no transport of soil particles from the base, independent of the level of hydraulic loading. That means that the openings in the granular filter or geotextile are so small that the soil particles are physically not able to pass the opening. This principle is illustrated in Figure 6 for granular filters.

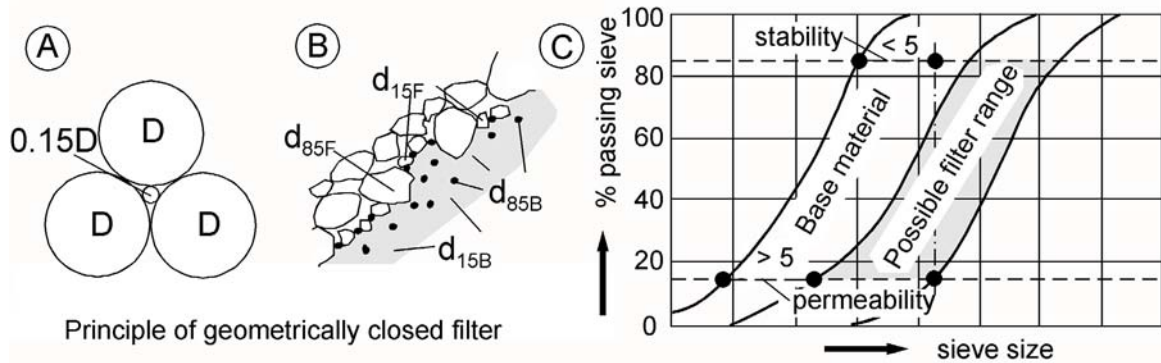

Figure 6 Principles of geometrically tight filters

The main design rules (criteria) for geometrically tight (closed) granular filters and geotextiles are summarized below. The more detailed information on design of geotextile filters is given in Pilarczyk (1999).

The soil tightness of the initial situation can be checked by means of the well-known criteria for granular filters:

- Interface stability (also called 'piping' criterion):

$$\frac{D_{f15}}{D_{b85}} \leq 4 \text{ to } 5 \quad (11)$$

where:

$D_{f15}$  is the grain size of the filter layer (or cover layer) which is exceeded by 15 % of the material by weight in m;

$D_{b85}$  is the grain size of the base material (soil) which is exceeded by 85 % of the material by weight in m.

The factor 4 in Eq. (11) was given by TERZAGHI. The factor 5 is determined for normal wide-graded materials. Sometimes a similar equation is defined as:

$$\frac{D_{f50}}{D_{b50}} < 6 \text{ to } 10 \quad (12)$$

However, Equation (12) is less general than Eq. (11) and can be used for 'small' gradation only. Therefore, Eq. (11) is recommended for general use. However, in the case of very 'wide' gradation the situation requires an additional check with respect to the internal migration. In this respect, an important parameter is the so-called 'uniformity coefficient'  $C_u$ , defined by Equation (13) and the shape of the sieve curve:

$$C_u = \frac{D_{b60}}{D_{b10}} \quad (13)$$

where:  $C_u$  is the coefficient of uniformity.

- Internal stability can be roughly judged by the following rules (Eq. 14):

$$D_{10} < 4 D_5 \quad (14a)$$

$$D_{20} < 4 D_{10} \quad (14b)$$

$$D_{30} < 4 D_{15} \quad (14c)$$

$$D_{40} < 4 D_{20} \quad (14d)$$

- permeability criterion

$$\frac{D_{f15}}{D_{b15}} > 5 \quad (15)$$

### 3.4.2 Summary of design rules for geotextiles

#### *Current definitions for geotextile openings*

There are a large number of definitions of the characteristic of geotextile openings. Moreover, there are also different test (sieve) methods for the determination of these openings (dry, wet, hydrodynamic, etc.) which depend on national standards. These all make the comparison of test results very difficult or even impossible. That also explains the necessity of international standardization in this field.

Some of the current definitions are listed below:

- $O_{90}$  corresponds with the average sand diameter of the fraction of which 90% of the weight remains on or in the geotextile (or 10 % passes the geotextile) after 5 minutes of sieving (method: dry sieving with sand);
- $O_{98}$  corresponds with the average sand diameter of the fraction of which 98% of the weight remains on or in the geotextile after 5 minutes of sieving.  $O_{98}$  gives a practical approximation of the maximum filter opening and therefore plays an important role in the sand tightness criterion for a geotextile in strong cyclic loading situations.  $O_{98}$  is also referred to as  $O_{\max}$ .
- $O_f$  filtration opening size (FOS).  $O_f$  is comparable with  $O_{95}$  (hydrodynamic sieve method);
- AOS apparent opening size (acc. to ASTM method), also called EOS (effective opening size). The AOS is determined by sieving spherical glass particles of known size through a geotextile. The AOS, also frequently referred to as  $O_{95}$  (dry sieve method), is defined as a standard sieve size,  $x$ , mm, for which 5% or less of the glass particles pass through the geotextile after a specified period of sieving;
- $D_w$  effective opening size which corresponds with the sand diameter of the fraction of which 10 %, determined by the wet sieve method, passes through the geotextile.  $D_w$  is comparable with  $O_{95}$ .

The transport of soil particles within a grain structure is possible when there is enough space and a driving force (groundwater pressure, hydraulic gradients within the soil). In most cases it is the intention to prevent the transport of small-sized soil particles in the subsoil and therefore the term soil tightness is used and not the term space for transport or pore volume (in the case of the transport of water the terms pore volume and water permeability are used). The relation between pore magnitude and grain diameter can be characterized by: pore diameter  $\approx$  20% of the grain diameter. Just as for the characterization of the performance of a grain structure with regard to the transport of soil particles, for geosynthetics, too, the term soil tightness is used.

As was mentioned before (Figure 6), in a theoretical case when the soil is composed of spheres of one-size diameter, all spheres can be retained if all apertures in the geosynthetic are smaller than the diameter of the spheres. Usually the soil consists of particles with different diameters and shapes, which is reflected in the particle-size distribution curves. Smaller particles can disappear straight across the geosynthetic by groundwater current. In this case the retained soil structure can function as a natural filter; see Figure 7. The better the soil particles are distributed, the better the soil tightness of the soil structure is effected. Smaller soil particles get stuck into the spaces between larger ones and the soil structure prevents the flow of fine particles. When certain particle-size fractions are lacking, the soil structure is not stacked very well and cavities develop through which erosion can occur. The displacement of soil particles not only depends on the soil tightness but also on the hydraulic gradient in the soil structure. Moreover, the dynamic effects due to heavy wave loading may not allow the forming of a natural filter, and the process of washing-out may continue.

According to some researchers the forming of a natural filter is only possible for stationary flow (CUR, 1993). However, this is also possible for non-stationary flow, for small values of the hydraulic gradients. For heavy wave attack (i.e. exposed breakwaters) this is usually not the case. In extreme situations, soil liquefaction is even possible. In such situations the soil particles can still reach the surface of a geotextile and be washed out.

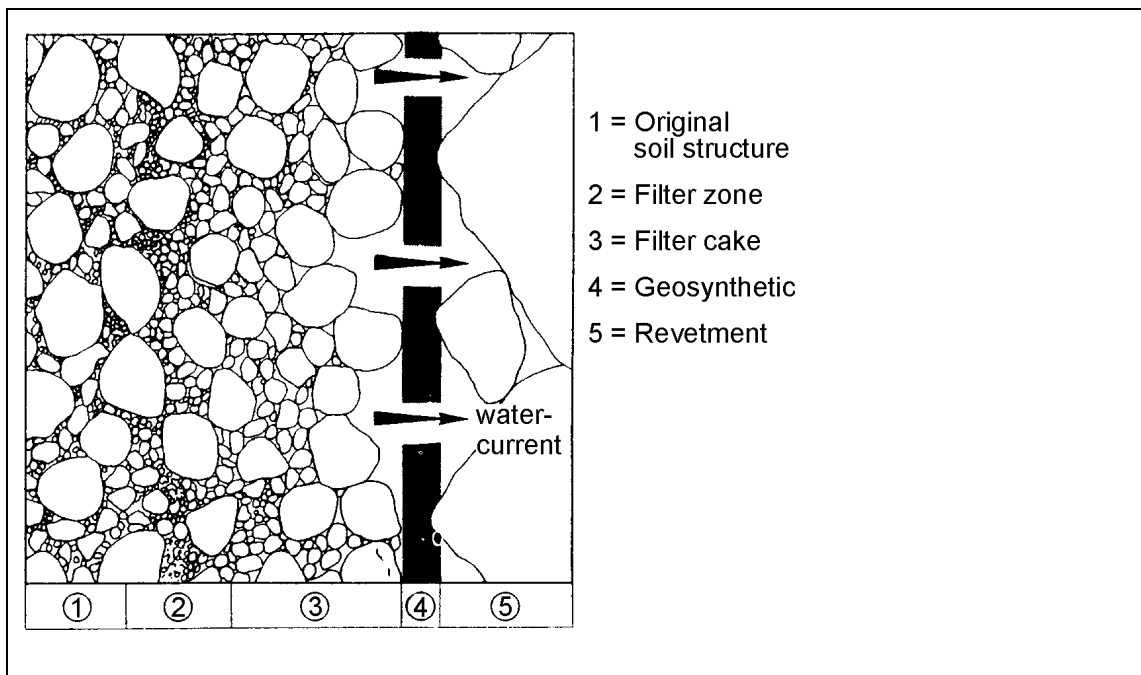

Figure 7 Schematic representation of a natural filter with a soil-retaining layer

In order to judge the risk of wash-out of soil particles through the geosynthetics, some aspects have to be considered. An important factor is the internal stability of the soil structure.

In the case of a loose particle stacking of the soil many small soil particles may pass through the geosynthetic before a stable soil structure is developed near the geosynthetic. Also, a proper compaction of soil is very important for the internal stability of soil. The internal stability is defined by the uniformity coefficient  $C_u$  (see Eq. 13). It is defined as  $D_{b60}/D_{b10}$ . If this ratio is smaller than 6 (to 10), the soil structure is considered internally stable.

In case of vibration, for instance caused by waves or by traffic, the stable soil structures can be disturbed. To avoid such situations, the subsoil has to be compacted in advance and a good junction between geosynthetic and subsoil has to be guaranteed and possibly, a smaller opening of geotextile must be chosen.

The shape of the sieve curve also influences the forming of a natural filter. Especially, when  $C_u > 6$ , the shape of the base gradation curve and its internal stability must be taken into account (Pilarczyk, 1999). For a self-filtering linearly graded soil, the representative size corresponds to the average grain size,  $D_{b50}$ . For a self-filtering gap graded soil, this size is equal to the lower size of the gap. For internally unstable soils, this size would be equivalent to  $D_{b30}$  in order to optimize the functioning of the filter system. It is assumed that the involved bridging process would not retrogress beyond some limited distance from the interface.

· *Soil tightness*

With respect to the soil tightness of geotextiles many criteria for geometric soil tightness have been developed and published in the past (Pilarczyk, 1999). An example of such design criteria, based on Dutch experience, is presented in Table 1. An additional requirement is that the soil should be internally stable. The internal stability of a grain structure is expressed in the ratio between  $D_{b60}$  and  $D_{b10}$ . As a rule this value has to be smaller than 10 to guarantee sufficient stability.

Table 1 Design requirements for geosynthetics with a filter and separation function

description filter	function/soil tightness
- stationary loading	$O_{90} \leq 1$ (to 2) $D_{b90}$
- cyclic loading with natural filter (stable soil structure)	$O_{98} \leq 1$ (to 2) $D_{b85}$
- cyclic loading without a natural filter	

- (unstable soil structure)
- . when wash-out effects acceptable  $O_{98} \leq 1.5 D_{b15}$
  - . when wash-out effects not acceptable  $O_{98} \leq D_{b15}$

However, in many situations additional requirements will be necessary, depending on the local situation. Therefore, for design of geometrically tight geotextiles the method applied in Germany can be recommended (see HEERTEN, 1982, PIANC, 1987, BAW, 1993). In this method a distinction is made between so-called stable and unstable soils. Soils are defined as unstable (susceptible to down-slope migration) when the following specifications is fulfilled:

- a proportion of particles must be smaller than 0.06 mm;
- fine soil with a plasticity index ( $I_p$ ) smaller than 0.15 (thus, it is not a cohesive soil);
- 50 percent (by weight) of the grains will lie in the range  $0.02 < D_b < 0.1$  mm;
- clay or silty soil with  $Cu < 15$ .

If the  $I_p$  is unknown at the preliminary design stage then the soil may be regarded as a problem soil if the clay size fraction is less than 50% of the silt size fraction.

The design criteria are presented in Table 2. More detailed information can be found in Pilarczyk (1999).

Table 2 Design criteria for geometrically soil-tight geotextiles

	soil type			
	$D_{b40} < 60 \mu\text{m}$		$D_{b40} > 60 \mu\text{m}$	
	stable soil	Instable soil	stable soil	instable soil
stationary loading	$O_{90} < 10 D_{b50}$ and $O_{90} < 2 D_{b90}$	$O_{90} < 10 D_{b50}$ and $O_{90} < D_{b90}$	$O_{90} < 5 D_{b10} Cu^{1/2}$ and $O_{90} < 2 D_{b90}$	$O_{90} < 5 D_{b10} Cu^{1/2}$ and $O_{90} < D_{b90}$
dynamic loading		$O_{90} < D_{b90}$ and $O_{90} < 0.3 \text{ mm}$ (300 $\mu\text{m}$ )	$O_{90} < D_{b90}$	$O_{90} < 1.5 D_{b10} Cu^{1/2}$ and $O_{90} < D_{b50}$ $O_{90} < 0.5 \text{ mm}$

( $O_{90}$  is determined by wet sieve method)

In the case of fine sand or silty subsoils, however, it can be very difficult to meet these requirements. A more advanced requirement is based on hydrodynamic sand tightness, viz. that the flow is not capable of washing out the subsoil material, because of the minor hydrodynamical forces exerted (although the apertures of the geotextile are much larger than the subsoil grains).

#### *Requirements concerning water permeability*

To prevent the forming of water pressure (uplift) in the structure, causing loss of stability, the geotextile has to be water permeable. One has to strive for the increase of water permeability of a construction in the direction of the water current. In the case of a riverbank protection it means that the permeability of the geotextile has to be larger than the permeability of the soil on which the geotextile has to be applied. In the case of a dike slope or dike foundation the geosynthetic is often applied on an impermeable layer of clay. Proper permeability of geotextiles is very important in respect to the stability of relatively less permeable cover layers as, for example, block and block mats. When a geotextile lies directly under the cover layer it considerably reduces the open area of the cover layer, and as a result the uplift forces increase (see example in Section 4.2). The water permeability of woven fabrics and nonwovens may decrease in the course of time owing to the fact that fine soil particles, which are transported by the groundwater flow from the subsoil, **block** the openings in the geotextile, or migrate into the pores of the geosynthetic (**clogging**).

To prevent mineral clogging, the pore size of the geotextiles has to be chosen as large as possible; but, of course, this pore size has still to meet the requirements for soil tightness. The danger of clogging increases when the soil contains more than 20% of silt or in the case of gap-grading of a soil. On the other

hand, there usually is no danger of clogging when the total hydraulic gradient (over the subsoil and geotextile together) is less than **3**, or when the subsoil is well graded. In all situations it holds that the soil must be internally stable. For less critical situations no clogging can be expected if:

$$Cu > 3: O_{95}/D_{b15} > 3; \quad (16a)$$

$$Cu < 3: \text{criterion of internal stability of soil should be satisfied} \quad (16b)$$

and/or geotextile with maximum opening size from  
soil-tightness criteria should be specified.

In respect to the water permeability of geosynthetics/geotextiles, a distinction should be made between "normal to the interface" and "parallel to the interface". For geotextile filters the permeability parallel to the interface is of importance, while for drainage structures the permeability normal to the interface is of most importance. As a general design criterion for flow normal to the interface one can hold that the water permeability of a geosynthetic/geotextile has to be greater than that of the soil at the side from where the water flow comes. As a rule one can keep to:

$$k_{\text{geotextile (filter)}} = k_{\text{soil}} \times \text{factor} \quad (17)$$

where  $k_s$  and  $k_g$  are usually (basically) defined for laminar conditions.

For normal (stationary) conditions and applications and clean sands a factor of 2 is sufficient to compensate the effect of blocking. If a geotextile is permeable with a factor of 10 more than the (non-cohesive) subsoil, overpressure will usually not occur, neither below the geosynthetic, nor in the case of reduced permeability caused by clogging or blocking. However, for special applications (i.e., for dam-clay cores with danger of clogging) this factor can be 50 or more.

The detailed treatment with respect to the effect of hydraulic loading on permeability characteristics of the geotextile and the possible interactions with the subsoil can be found in (Van Santvoort, 1994 and Pilarczyk, 1999)). However, the basic information on this aspect as far as it is needed for total design with geotextiles, is given hereafter.

#### *Water permeability normal to the interface*

The function of the water permeability requirement in the total approach of designing with geotextiles is to bring the design of the filter into harmony with the subsoil. The requirement that excess pressures should not occur means that the eventual loss of stability at the filter occurs no sooner than the similar loss of stability does in the subsoil (i.e. migration of particles, softening of the subsoil and resulting sliding, etc.) as a consequence of groundwater flow (critical gradients). The basic (starting) requirement is that the gradient over the geotextile should maximally be equal to the gradient of the subsoil:

$$i_n \leq i_b \quad (18)$$

where:  $i_b$  is the gradient in sublayer (or in subsoil,  $i_s$ ) and  $i_n$  is the gradient normal to the geotextile.

The permeability of a geotextile can be characterized by the permeability coefficient  $k_g = k_n$  (m/s) or by the permittivity  $\psi$  (1/s), see also Figure 8. Permittivity can be directly calculated from test results and expresses the rate of flow through the geotextile per unit area and per unit hydraulic head, and it is also defined as permeability per unit thickness of geotextile :

$$\psi = \frac{Q}{A \Delta h_g} = \frac{v_f}{\Delta h_g} = \frac{k_n}{T_g} \quad (19)$$

where:

- $\psi$  is the permittivity in 1/s;
- $Q$  is the flow rate through the geotextile in  $\text{m}^3/\text{s}$ ;
- $v_f$  is filtration velocity in m/s;
- $A$  is the surface area of geotextile in  $\text{m}^2$ ;
- $\Delta h_g$  is the hydraulic head difference across the geotextile in m;
- $k_n$  is the permeability coefficient of the geotextile ( $k_g$ ), normal to the interface, in m/s;
- $T_g$  is the thickness of the geotextile in m.

N.B. the term  $k_n/T_g$  in Eq. 19 is often used for rough estimation of the permeability coefficient for other (not tested) thicknesses for the same type of geotextile.

The main problem of using permittivity is the definition of the thickness of geotextile. Usually a thickness under the normal stress of 2 kPa is applied. The definitions and an example of test results concerning the determination of permittivity and permeability for geotextiles are presented in Figure 8.

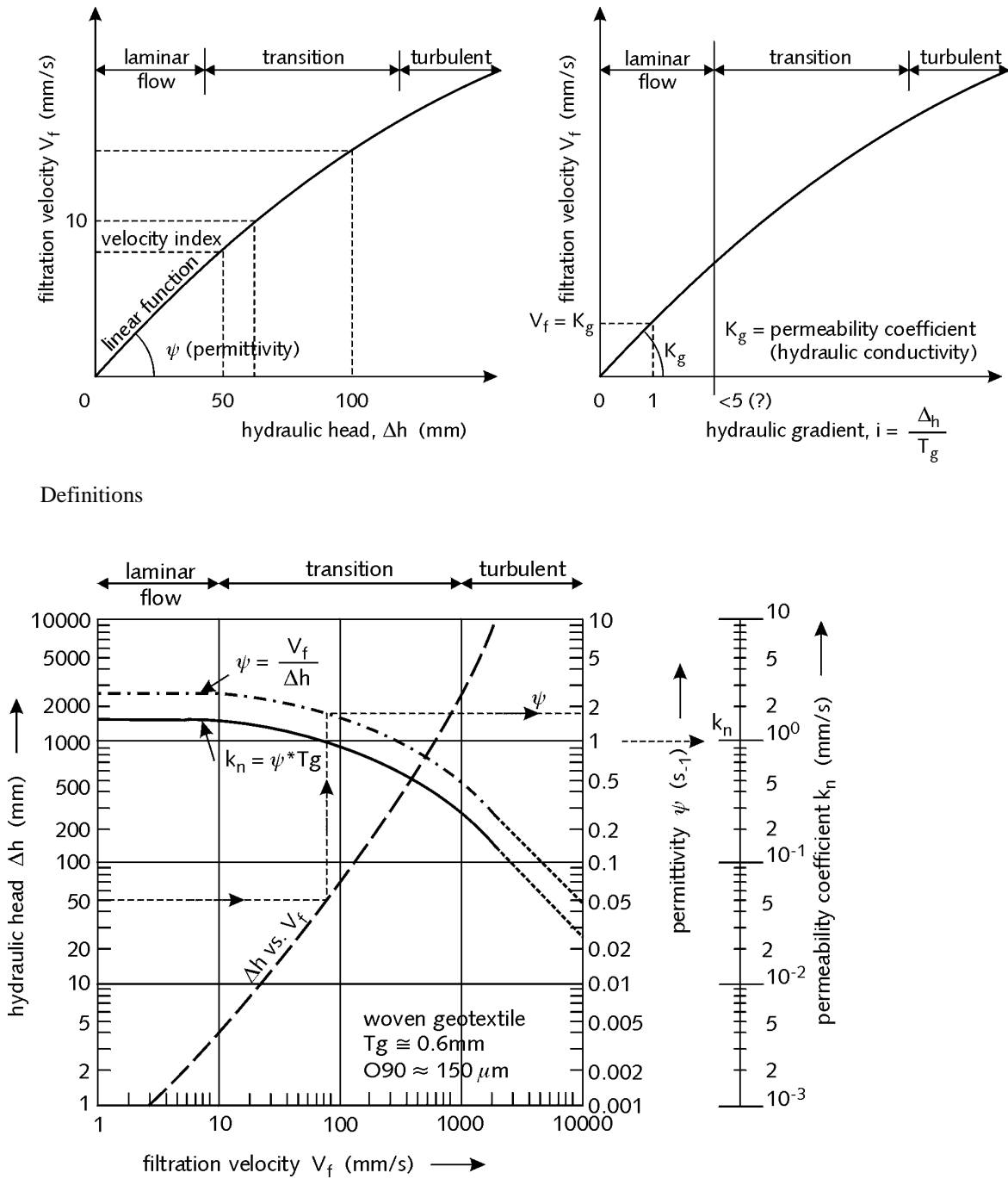

Figure 8 An example of the relationships between between permittivity and hydraulic conductivity (permeability coeff.) as a function of hydraulic head

Combining formulas (17) and (18) with formula (19), and applying a continuity principle,

$$k_n i_n = k_b i_b \tag{20}$$

where:  $k_b$  is the permeability coefficient of the base material (subsoil,  $k_s$ ) in m/s, and  $i_b$  is the gradient in the base material;

it provides:

$$\psi = c k_b \frac{i_b}{\Delta h_g} \approx c_\psi k_b \quad (21)$$

In general, permittivity of a certain geotextile is a function of the hydraulic head. Only in the zone of laminar flow the permittivity is more or less constant (see Figure 8). When permittivity is defined outside this zone, the associated hydraulic head ( $Dh$ ) should be mentioned.

The total safety factor  $c_y$  incorporates a number of uncertainties (i.e., permeability of soil, the loss of permeability due to the effects of clogging and stress, etc.) and, depending on application, can be equal to  $10^3$  for clean sands and up to  $10^5$  for critical soils and severe applications in dams (see CFGG, 1986). The last value seems to be rather conservative.

Holtz et al. (1997) propose to use, additionally to other permeability criteria, the permittivity criterion directly related to the soil type defined by a certain percentage of passing the sieve of 0.075 mm. These criteria have originally been established by the U.S. Federal Highway Administration (FHWA, 1995). These permittivity requirements are:

- $\psi \geq 0.5 \text{ sec}^{-1}$  for soils with < 15% passing the 0.075 mm sieve;
- $\psi \geq 0.2 \text{ sec}^{-1}$  for soils with 15 to 50% passing the 0.075 mm sieve;
- $\psi \geq 0.1 \text{ sec}^{-1}$  for soils with > 50% passing the 0.075 mm sieve.

The flow rate  $Q$  through the geotextile can be defined as:

$$Q = v_f A = \psi \Delta h_g A = k_n A i_g \quad (22)$$

#### Discussion

There are a large number, often very unclear and confusing definitions of permeability of geotextiles, especially when the permeability of geotextile must match the permeability of a certain soil. The basic equation, both for soil and geotextile, is the Darcy's equation;  $v_f = k \times i$ , which is valid for laminar flow conditions.

The hydraulic gradient  $i$  is the average hydraulic gradient in the soil. For example, the gradient along (parallel to) geotextile in revetments with a thick granular layer above, loaded by run-up and run-down, often a tangent of slope angle can be applied ( $\tan \alpha$ ). However, for thin granular filters (layers) this gradient can be much larger than  $\tan \alpha$ . For other applications  $i$  can be estimated by using a conventional flow net analysis for seepage through dikes and dams or from a rapid drawdown analysis. The permeability of geotextiles is characterized by a number of different (national) index tests. Therefore, at this moment, the standard specification sheets provided by manufacturers include such definitions as: the permeability (filtration velocity,  $v_f$ ) at the hydraulic head equal to 50, 100 or even 250 mm, permittivity defined at the standard filtration velocity ( $v_f$ ) equal to 10 mm/s (at a certain hydraulic head), the head loss index corresponding to a filtration velocity of 20 mm/s, etc.

Actually, CEN (1998) prepared a European standard introducing only one index test, so-called 'Velocity Index', which defines the filtration velocity corresponding to a head loss of 50 mm across a specimen. The flow velocity  $v_f$  expressed in mm/s equals the unit discharge  $q$  expressed in  $l/m^2 \text{ s}$ . However, to be able to draw conclusion about the proper choice of permeability for various conditions and applications, it is necessary to perform (to measure) the full permeability characteristics and prepare a collective plot of the velocity  $v_f$  and head loss  $Dh$  for each specimen. The test range must be sufficiently wide to allow also the determination of permeability parameters for laminar flow. If the full permeability characteristics of the geotextile product have previously been established, then for checking purposes it can be sufficient to determine the velocity index at a head loss of 50 mm only.

In case that only one or two test data with standard index specifications ( $v_f$ ,  $\Delta h$ , and  $T_g$ ) are known, the approximate estimation of permeability can be done by using the following equation:  $v_f = k i^m$ , where  $i = \Delta h/T_g$  and  $0.5 \leq m \leq 1.0$  ( $m = 1$  for laminar flow and  $m = 0.5$  for turbulent flow). When only one point is available the rough approximation can be obtained by applying  $m = 0.7$ .

By plotting a line on a log-log paper through two points the exponent  $m$  can be determined, and for  $i = 1$ ,  $k$  can be approximated. By using this equation the permeability can be roughly extrapolated to the required conditions/definitions, for example,  $k_g = v_f T_g / \Delta h$  or  $k_g = \psi T_g$  at  $\Delta h = 50 \text{ mm}$ , or  $k_g$  at  $v_f = 10 \text{ mm/s}$ , or  $k_g$  or  $\psi$  for laminar conditions, and can be used as a first approximation. In case of doubt, more data or additional tests can be requested.

The permeabilities defined outside the laminar zone can also be interpreted in the following way, for

example, if  $k_g$  established at  $v_f = 10$  mm/s is equal or larger than  $k_{s(\text{soil})}$ , the geotextile fulfills the requirement of permeability for filtration velocities (in the soil) lower than 10 mm/s. For larger filtration velocities the new estimation of  $k_g$  is needed, related to the higher  $v_f$ , to check the requirement  $k_g > k_s$ , because  $k_g$  will decrease for higher  $v_f$  in transition or turbulent flow zone.

With regard to the hydraulic efficiency of the geotextile filter, full advantage should be taken on the permissible upper limits of the opening size, provided the required mechanical filter effectiveness (soil-tightness) is ensured (DVWK, 1993). The reason for this is that an open (and possibly, thicker) structure is generally superior to a dense structure with regard to the filter stability. Thus, when the permeability is decisive for the design, the largest admissible opening size resulting from the soil-tightness criteria should be used to ensure the permeability as high as possible. There are usually no problems with obtaining a sufficient permeability when  $1 \leq O_{90}/D_{90} < 2$  is applied as a soil-tightness criterion. Research results (MLYNAREK, 1994) indicate that the permeability of a soil-geotextile system is mainly defined by the permeability of a soil. However, the geotextile permeability will decrease in soil due to compression. It is of special importance for thick non-wovens. Therefore, the factor of safety should be increased accordingly to account for the critical nature of the application, type of geotextile, and the severity of the soil and hydraulic conditions.

This discussion indicates that there are still much uncertainties in the proper application of the permeability criteria. However, for normal (stationary) conditions and stable soils it is usually not a real problem. For critical projects, performance tests simulating soil-geotextile interaction can be recommended.



## 4 STABILITY CRITERIA FOR PLACED BLOCKS AND BLOCK MATS

### 4.1 System description

Placed block revetments (or stone/block pitching) are a form of protection lying between revetments comprised of elements which are disconnected, such as rubble, and monolithic revetments, such as asphalt/concrete slabs. Individual elements of a pitched block revetment are placed tightly together in a smooth pattern. This ensures that external forces such as waves and currents can exert little drag on the blocks and also that blocks support each other without any loss of flexibility when there are local subsoil irregularities or settlement.

A (concrete) block mat is a slope revetment made of (concrete) blocks that are joined together to form a "mat", see Figure 9. The interconnection may consist of cables from block to block, of hooks connecting the blocks, or of a geotextile on which the blocks are attached with pins, glue or other means. The spaces between the blocks are usually filled with rubble, gravel or slag.

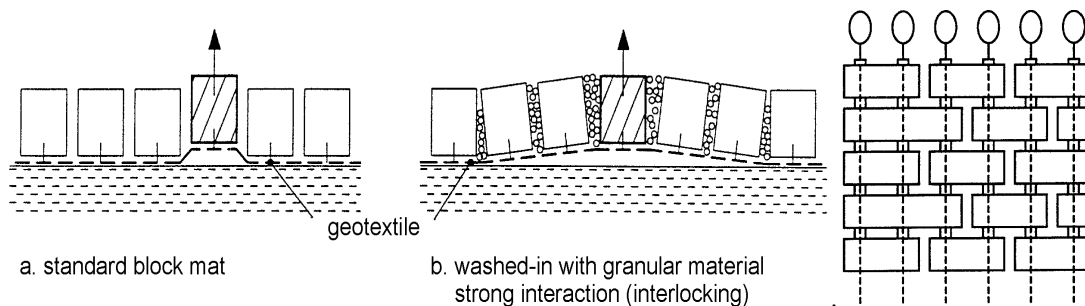

Figure 9 Examples of block mats

The major advantage of block mats is that they can be laid quickly and efficiently and partly under water. Block mats are more stable than a setting of loose blocks, because a single stone cannot be moved in the direction perpendicular to the slope without moving other nearby stones. It is essential to demand that already with a small movement of an individual stone a significant interactive force with the surrounding stones is mobilised. Large movements of individual blocks are not acceptable, because transport of filter material may occur. After some time, this leads to a serious deformation of the surface of the slope.

The block mats are vulnerable at edges and corners. If two adjacent mats are not joined together, then the stability is hardly larger than that of pitched loose stones.

### 4.2 Design rules with regard to wave load

The usual requirement that the permeability of the cover layer should be larger than that of the underlayers cannot be met in the case of a closed block revetment and other systems with low permeable cover layer. The low permeable cover layer introduces uplift pressures during wave attack. In this case the permeability ratio of the cover layer and the filter, represented in the leakage length, is found to be the most important structural parameter, determining the uplift pressure. This is also the base of analytical model.

The analytical model is based on the theory for placed stone revetments on a granular filter (CUR/TAW, 1995). In this calculation model, a large number of physical aspects are taken into account (see Figures 1, 2 and 6). In short, in the analytical model nearly all physical parameters that are relevant to the stability have been incorporated in the "leakage length" factor. The final result of the analytical model may, for that matter, again be presented as a relation such as Eqs. 2 or 3 where  $F = f(\Lambda)$ . For systems on a filter layer, the leakage length  $\Lambda$  is given as:

$$\Lambda = \sqrt{\frac{bDk}{k'}} \quad \text{or} \quad \Lambda/D = \sqrt{\frac{bk}{Dk'}} \quad (23a)$$

where:  $\Lambda$ =leakage length [m]  $b_f$  = thickness of the filter layer (m),  $k_f$  = permeability of the filter layer or subsoil (m/s), and  $k'$  = permeability of the top (cover)layer (m/s).

With a system without a filter layer (directly on sand or clay, without gullies being formed under the top layer) not the permeability of the filter layer, but the permeability of the subsoil (eventually with gullies/surface channels) is filled in. For the thickness of the filter layer it is examined to which depth changes at the surface affect the subsoil. One can fill in 0.5 m for sand and 0.05 m for clay. The values for  $D$  and  $\Delta$  depend on the type of revetment. When schematically representing a block on a geotextile on a gully in sand, the block should be regarded as the top layer and the combination of the geotextile and the small gully as the filter layer (Figure 10).

Figure 10 Schematization of a revetment with gully (cavity)

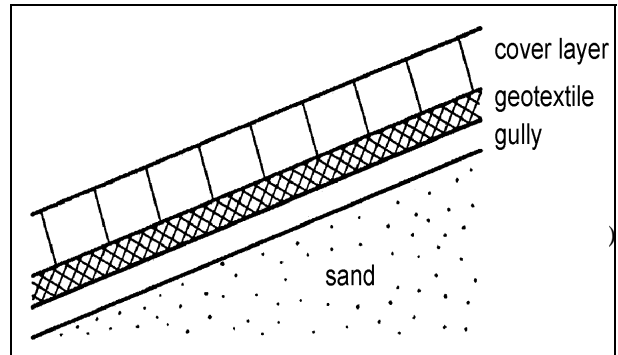

The leakage length can be calculated using:

$$\Lambda = \sqrt{\frac{(k_f d_g + k_g T_g) D}{k'}} \quad (23b)$$

with:

$k_f$  = permeability of the filter layer (gully) (m/s),  $d_g$  = gully depth (m),  $k_g$  = permeability of the geotextile (m/s),  $T_g$  = thickness of the geotextile (m),  $D$  = thickness of the top layer (m), and  $k'$  = permeability of the top layer (m/s).

In the case of a geotextile situated directly under the cover layer, the permeability of the cover layer decreases drastically. Since the geotextile is pressed against the cover layer by the outflowing water, it should be treated as a part of the cover layer.

The water flow through the cover layer is concentrated at the joints between the blocks, reaching very high flow velocities and resulting in a large pressure head over the geotextile. The presence of a geotextile may reduce  $k'$  by a factor 10 or more (see Figure 11).

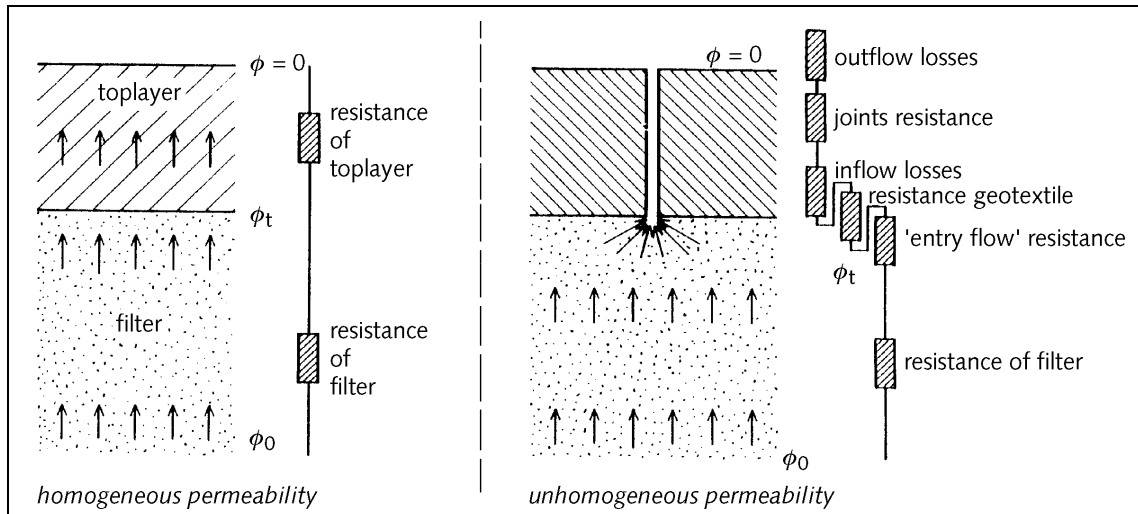

Figure 11 Combined flow resistance determining the permeability of a system

The leakage length clearly takes into account the relationship between  $k_f$  and  $k'$  and also the thickness of the cover layer and the filter layer. For the theory behind this relationship, reference should be made to literature (see Klein Breteler et al, 1998 and CUR/TAW, 1995). The pressure head difference which develops on the cover layer is larger with a large leakage length than with a small leakage length. This is mainly due to the relationship  $k_f/k'$  in the leakage length formula. The effect of the leakage length on the dimensions of the critical wave for semi-permeable revetments is apparent from the following equations:

$$\frac{H_{scr}}{\Delta D} = f \left( \frac{D}{\Lambda \xi_{op}} \right)^{0.67} = \frac{H_{scr}}{\Delta D} = f \left( \frac{D k'}{b k} \right)^{0.33} \xi_{op}^{-0.67} = \frac{H_{scr}}{\Delta D} = F \xi_{op}^{-0.67} \quad (24)$$

where:  $H_{scr}$  = significant wave height at which blocks will be lifted out [m];  $\xi_{op} = \tan\alpha/\sqrt{(H_s/(1.56T_p^2))}$  = breaker parameter;  $T_p$  = wave period [s];  $\Delta$  = relative volumetric mass of cover layer =  $(\rho_s - \rho)/\rho$ ;  $f$  = stability coefficient mainly dependent on structure type and with minor influence of  $\Delta$ ,  $\tan\alpha$  and friction, and  $F$  = total (black-box) stability factor.

These equations indicate the general trends and have been used together with measured data to set up the general calculation model (CUR/TAW, 1995, Pilarczyk, 1998). This method works properly for placed/pitched block revetments and block mats within the following range:  $0.01 < k'/k_f < 1$  and  $0.1 < D/b_f < 10$ . Moreover, when  $D/\Lambda > 1$  use  $D/\Lambda = 1$ , and when  $D/\Lambda < 0.01$  use  $D/\Lambda = 0.01$ . The range of the stability coefficient is:  $5 < f < 15$ ; the higher values refer to the presence of high friction among blocks or interlocking systems. The following values are recommended for block revetments:

$f = 5$  for static stability of loose blocks (no friction between the blocks),

$f = 7.5$  for static stability of a system (with friction between the units),

$f = 10$  for tolerable/acceptable movement of a system at design conditions.

From these equations, neglecting the usually minor variations of 'f', it appears that:

- An increase in the volumetric mass,  $\Delta$ , produces a proportional increase in the critical wave height. If  $\rho_b$  is increased from 2300 to 2600kg/m<sup>3</sup>,  $H_{scr}$  is increased by about 23%,

- If the slope angle is reduced from 1:3 to 1:4 ( $\tan\alpha$  from 0.33 to 0.25)  $H_{scr}$  is increased by about 20% (due to the breaker parameter,  $\xi_{op}$ ),

- An increase of 20% in the thickness of the cover layer,  $D$ , increases  $H_{scr}$  by about 27%,

- A 30% reduction in the leakage length,  $\Lambda$ , increases  $H_{scr}$  by about 20%. This can generally be achieved by halving the thickness of the filter layer or by doubling the  $k'/k_f$  value. The latter can be achieved by approximation, by:

- reducing the grain size of the filter by about 50%, or
- by doubling the number of holes in (between) the blocks, or
- by making hole sizes 1.5 times larger, or
- by doubling joint width between blocks.

*EXAMPLE: In 1983 the Armorflex mat on a slope 1:3 was tested on prototype scale at the Oregon State University: closed blocks with thickness  $D = 0.12$  m and open area 10% on two types of geotextiles and very wide-graded subsoil ( $d_{15} = 0.27$  mm,  $d_{85} = 7$  mm).*

*In the case of a sand-tight geotextile the critical wave height (instability of mat) was only  $H_{scr} = 0.30$  m. In the case of an open net geotextile (opening size about 1mm) the critical wave height was more than 0.75 m (maximum capacity of the wave flume).*

*The second geotextile was 20 times more permeable than the first one. This means that the stability increased by factor  $20^{0.33} = 2.7$ .*

In most cases the permeabilities of the cover layer and sublayer(s) are not exactly known. However, based on the physical principles as described above, the practical 'black-box' method has been established where parameter  $\Lambda$  and coefficient 'F' are combined to one stability factor 'F'. F depends on the type of structure, characterised by the ratios of  $k'/k_f$  and  $D/b_f$ . With the permeability formulas from (CUR/TAW, 1995) it is concluded that the parameter  $(k'/k_f)(D/b_f)$  ranges between 0.01 and 10, leading to a subdivision into 3 ranges of one decade each. Therefore the following types are defined:

- a) Low stability:  $(k'/k_f)(D/b_f) < 0.05 \dots 0.1$
- b) Normal stability:  $0.05 \dots 0.1 < (k'/k_f)(D/b_f) < 0.5 \dots 1$
- c) High stability:  $(k'/k_f)(D/b_f) > 0.5 \dots 1$

For a cover layer lying on a geotextile on sand or clay, without a granular filter, the leakage length cannot be determined because the size of  $b_f$  and  $k$  cannot be calculated. The physical description of the flow is different for this type of structure. For these structures there is no such a theory as for the blocks on a granular filter. However, it has been experimentally proved that Eqs. 3b or 24 are also valid for these structures.

It can be concluded that the theory has led to a simple stability formula (Eq. 24) and a subdivision into 4 types of (block) revetment structures:

- a1) cover layer on granular filter possibly including geotextile, low stability;
- a2) cover layer on granular filter possibly including geotextile, normal stability;
- a3) cover layer on geotextile on sand;
- a4) cover layer on clay or on geotextile on clay.

The coefficient, F, is quantified for each structure type by way of fitting Eq. 3b to the results of a large collection of results of model studies from all over the world. Only large-scale studies are used because both the waves and the wave induced flow in the filter should be well represented in the model. In the classification of structures according to the value of  $(k'D/k_f b_f)$ , the upper limit of  $(k'D/k_f b_f)$  is 10 times the lower limit. Therefore the upper limit of F of each structure type (besides a1.1) is assumed  $10^{0.33} = 2.14$  times the lower limit, since  $F = f(k'D/k_f b_f)^{0.33}$ . A second curve is drawn with this value of F. In Table 3 all available tests are summarised and for each type of structure a lower and upper boundary for the value of F is given (see also an example in Figure 12). The lower boundary gives with Eq. 3b a stability curve below which stability is guaranteed. Between the upper and lower boundary the stability is uncertain. It depends on various unpredictable influences whether the structure will be stable or not. The upper boundary gives a curve above which instability is (almost) certain.

Table 3 Lower and upper value for F

type	description	low F		high F	usual F
					(average value)
a1.1	pitched irregular natural stones on granular filter	2.0	3.0	2.5	
a1.2	loose blocks/basalt on granular filter, low stability	3.0		5.0	3.5
a2	loose blocks on granular filter, normal stability	3.5		6.0	4.5
a3	loose blocks on geotextile on compacted sand/clay	4.0		7.0	5.0
a4	linked/interlocked blocks on geotextile on good clay or on fine granular filter	5.0		8.0	6.0

The results for structure type a3 (blocks on geotextile on sand) may only be applied if the wave load is small ( $H_s < 1$  or 1.5m (max.)) or to structures with a subsoil of coarse sand ( $D_{50} > 0.3$  mm) and a gentle slope

( $\tan\alpha < 0.25$ ), because geotechnical failure is assumed to be the dominant failure mechanism (instead of uplift of blocks). The good compaction of sand is essential to avoid sliding or even liquefaction. For loads higher than  $H = 1.2$  m, a well-graded layer of stone on a geotextile is recommended (e.g. layer 0.3-0.5 m for  $1.2 \text{ m} < H < 2.5 \text{ m}$ ).

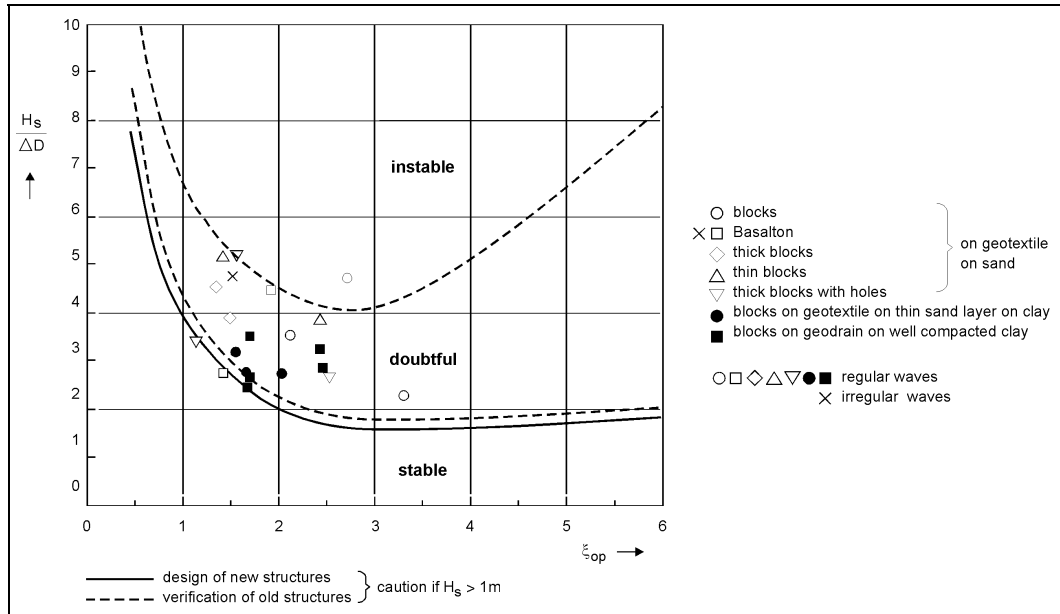

Figure 12 Example of a stability function for type a3 (loose blocks on geotextile on sand)

The results for structure type a4 can be applied on the condition that clay of high quality and with a smooth surface is used. A geotextile is recommended to prevent erosion during (long duration) wave loading. The general design criteria for geotextiles on cohesive soils are given by Pilarczyk (1999).

In the case of loose blocks an individual block can be lifted out of the revetment with a force exceeding its own weight and friction. It is not possible with the cover layers with linked or interlocking blocks. Examples of the second type are: block mattresses, ship-lap blocks and cable mats. However, in this case high forces will be exerted on the connections between the blocks and/or geotextile. In the case of blocks connected to geotextiles (i.e. by pins), the stability should be treated as for loose blocks in order to avoid the mechanical abrasion of geotextiles by moving blocks. The lower boundary of stability of cabled mats can be increased by a factor of 1.25 (or 1.5, if additionally grouted) in comparison with loose blocks. Such an increase of stability is only allowable when special measures are taken with respect to the proper connection between the mats. The upper boundary of stability ( $F = 8$ ) remains the same for all systems. Application of this higher stability requires optimization of design. This optimization technique (incl. application of geometrically open but stable filters and geotextiles) can be found in (CUR, 1993 and CUR/TAW, 1995).

To be able to apply the design method for placed stone revetments under wave load to other semi-permeable systems, the following items may be adapted: the revetment parameter  $F$ , the (representative) strength parameters  $\Delta$  and  $D$ , the design wave height  $H_s$  and the (representative) leakage length  $\Lambda$ . The basic formulas of the analytical model are presented in CUR/TAW, 1995 and Pilarczyk, 1998. Table 4 gives an overview of useable values for the revetment constant  $F$  in the black-box model for linked blocks (block mats).

Table 4 Recommended values for the revetment parameter F for blockmats (the lower values refer to blocks connected to geotextile while the higher ones refer to cabled blocks).

Type of revetment		F (-)
Linked blocks on geotextile on sand		5 to 6
Linked blocks on geotextile on clay	good clay	5 to 6
	Mediocre (sandy) clay	4.5 to 5
Linked blocks on a granular filter	favourable construction	5 to 6
	normal construction	4 to 5
	unfavourable construction	3 to 4

The terms "favourable", "normal" and "unfavourable" refer to the composition of the granular filter and the permeability-ratio of the top layer and the filter layer (see CUR/TAW, 1995). In a case of fine granular filter and relatively permeable top layer the total composition can be defined as "favourable". In a case of very coarse granular layer and less permeable top layer the composition can be defined as "unfavourable". In a case of blocks connected to a geotextile and concrete-filled mattresses on a filter layer the construction can be usually defined as between "unfavourable" and "normal", and the stability factor  $F = 3.0$  to  $3.5$  (max.  $4.0$ ) can be applied. For blockmats and permeable mattresses on sand  $F = 5$  (max.  $6.0$ ) can be applied. The higher values can also be used in cases that the extreme design loading is not very frequent or when the system is (repeatedly) washed in by coarse material providing additional interlocking.

This wide range of recommended values for **F** only gives a first indication of a suitable choice.

Furthermore it is essential to check the geotechnical stability with the design diagrams (see for example Figure 4 and for a full set of diagrams see Pilarczyk (1998, 1999).

## 5 STABILITY CRITERIA FOR CONCRETE-FILLED MATTRESSES

### 5.1 Concrete Mattresses

Characteristic of concrete mattresses are the two geotextiles with concrete or cement between them. The geotextiles can be connected to each other in many patterns, which results in a variety of mattress systems, each having its own appearance and properties. Some examples are given in Figure 13.

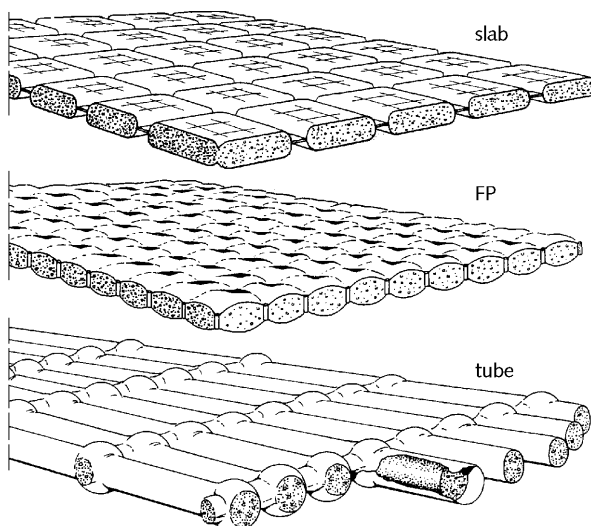

Figure 13 Examples of concrete-filled mattresses

The permeability of the mattress is one of the factors that determine the stability. It is found that the permeability given by the suppliers is often the permeability of the geotextile, or of the so-called Filter Points (Figure 14). In both cases, the permeability of the whole mattress is much smaller. A high permeability of the mattress ensures that any possible pressure build-up under the mattress can flow away, as a result of which the uplift pressures across the mattress remain smaller.

In general, with a subsoil of clay and silty sand the permeability of the mattress will be higher than the permeability of the subsoil. Therefore the water under the mattress can usually be discharged without excessive lifting pressures on the mattress.

The permeability of the mattress will be lower than the permeability of the subsoil or sub layers if a granular filter is applied, or with a sand or clay subsoil having an irregular surface (gullies/cavities between the soil and the mattress). This will result in excessive lifting pressures on the mattress during wave attack.

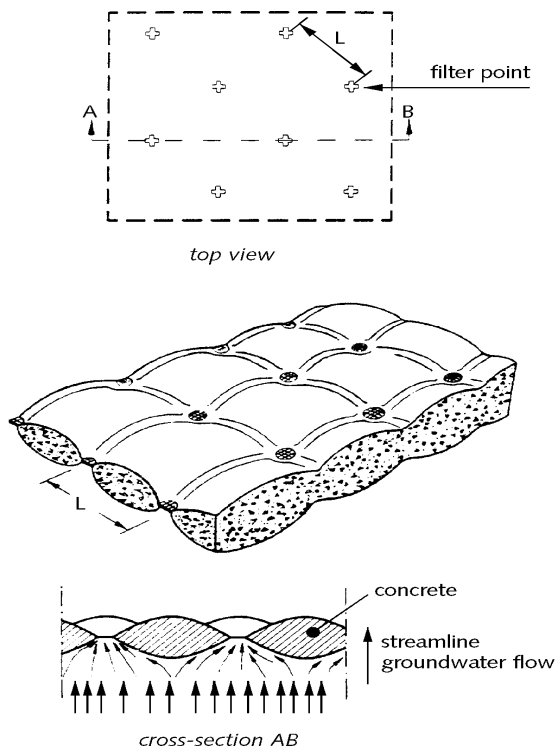

Figure 14, Principles of permeability of Filter Point Mattress

## 5.2 Design rules with regard to wave load

The failure mechanism of the concrete mattress is probably as follows:

- First, cavities under the mattress will form as a result of uneven subsidence of the subsoil. The mattress is rigid and spans the cavities.
- With large spans, wave impacts may cause the concrete to crack and the spans to collapse. This results in a mattress consisting of concrete slabs which are coupled by means of the geotextile.
- With sufficiently high waves, an upward pressure difference over the mattress will occur during wave run-down, which lifts the mattress (Figure 1).
- The pumping action of these movements will cause the subsoil to migrate, as a result of which an S-profile will form and the revetment will collapse completely.

It is assumed that local settlement of the subsoil will lead to free spans of the concrete mattress. Then, the wave impact can cause the breaking of these spans, if the ratio of  $H_s/D$  is too large for a certain span length. A calculation method is derived on the basis of an empirical formula for the maximum wave impact pressure and the theory of simply supported beams. The collapsing of small spans (less than 1 or 2 m) is not acceptable, since these will lead to too many cracks.

The empirical formula for the wave impact is (Klein Breteler et al 1998):

$$\frac{F_{impact}}{\rho g} = 7.2 H_s^2 \tan \alpha \quad (25)$$

With:  $F_{impact}$  = impact force per m revetment (N).

Calculation has resulted in an average distance between cracks of only 10 to 20 cm for a 10 cm thick mattress and wave height of 2 m. This means that at such a ratio of  $H_s/D$  the wave impacts will chop the mattress to pieces. For a mattress of 15 cm thick and a wave height of 1.5 m the crack distance will be in the order of 1 m.

Apart from the cracks due to wave impacts, the mattress should also withstand the uplift pressures due to wave attack. These uplift pressures are calculated in the same way as for block revetments. For this damage mechanism the leakage length is important.

In most cases the damage mechanism by uplift pressures is more important than the damage mechanism by impact.

The representative/characteristic values of the leakage length for various mattresses can be assumed as follow:

Mattress	Leakage length $\Lambda$ (m)		
	on sand <sup>*)</sup>	on sand <sup>**)</sup>	on filter
Standard - FP	1.5	3.9	2.3
FPM	1.0	3.9	2.0
Slab	3.0	9.0	4.7
Articulated (Crib)	0.5	1.0	0.5

<sup>\*)</sup> good contact of mattress with sublayer (no gullies/cavities underneath)

<sup>\*\*)</sup> pessimistic assumption: poor compaction of subsoil and presence of cavities under the mattress



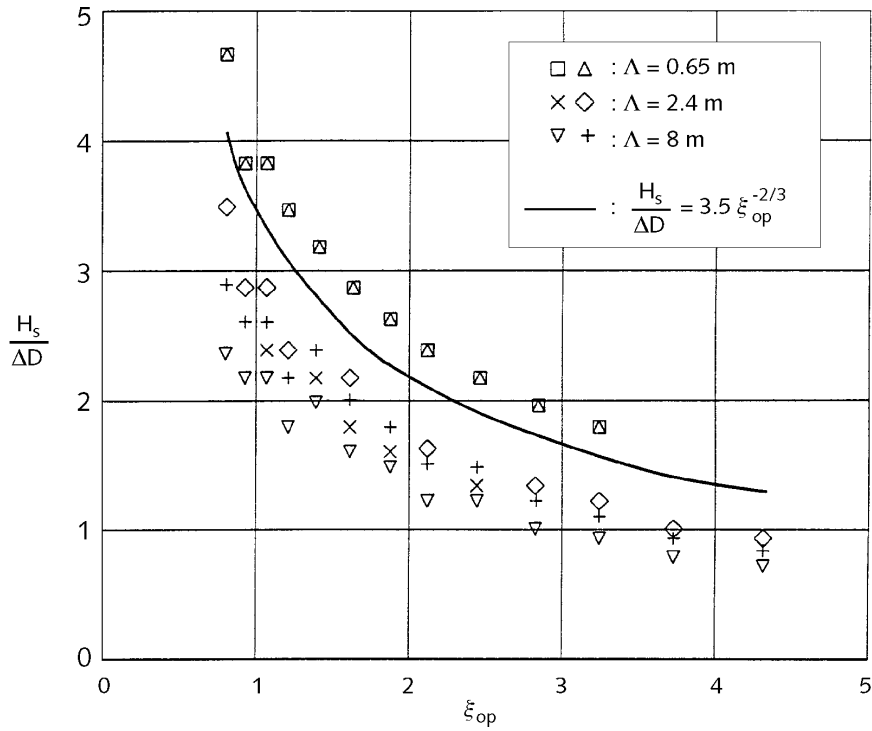

Figure 15 Calculation results for concrete mattresses ( $H_s/\Delta D < 4$  because of acceptable crack distance due to impacts on spans).

Taking into consideration the above failure mechanisms, the following design (stability) formula has been derived for the mattresses (Eq. 3b):

$$\frac{H_s}{\Delta D} = \frac{F}{\xi_{op}^{2/3}} \quad \text{with:} \quad \left[ \frac{H_s}{\Delta D} \right]_{\max} = 4 \quad (26)$$

with:

$$D = \frac{\text{mass per m}^2}{\rho_s} \quad (\text{which can be called } D_{\text{effective}} \text{ or } D_{\text{average}})$$

$\Delta =$  relative volumetric mass of the mattress (-) =  $(\rho_s - \rho)/\rho$   
 $\rho_s =$  volumetric mass of concrete ( $\text{kg/m}^3$ )  
 $F =$  stability factor (see below)

For an exact determination of the leakage length, one is referred to the analytical model (Klein Breteler et al 1998). However, besides the mattresses of a type as, for example, the tube mat (Crib) with relative large permeable areas, the other types are not very sensitive to the exact value of the leakage length. It can be recommended to use the following values of F in design calculations:

- $F = 2.5$  or  $(\leq 3)$  - for low-permeable mattresses on (fine) granular filter,
- $F = 3.5$  or  $(\leq 4)$  - for low-permeable mattress on compacted sand,
- $F = 4.0$  or  $(\leq 5)$  - for permeable mattress on sand or fine filter ( $D_{f15} < 2 \text{ mm}$ ).

The higher values can be applied for temporary applications or when the soil is more resistant to erosion (i.e. clay), and the mattresses are properly anchored.

## 6 STABILITY OF GABIONS

### 6.1 Introduction

Gabions are made of rectangular baskets of wire mesh, which are filled with stones. The idea of the protection system is to hold the rather small stones together with the wire mesh. Waves and currents would have easily washed away the small stones, but the wire mesh prevents this. A typical length of gabions is 3 to 4 m, a width of 1 to 3 m and a thickness of 0.3 to 1 m. The gabions with small thickness (less than 0.5 m) and large length and width are usually called Reno-mattresses.

An important problem of this protection system is the durability. Frequent wave or current attack can lead to a failure of the wire mesh because of the continuously moving grains along the wires, finally cutting through. Another problem is the corrosion of the mesh. Therefore meshes with plastic coating or corrosion resistant steel are used. On the other hand the system is less suitable where waves and currents frequently lead to grain motion.

### 6.2 Hydraulic loading and damage mechanisms

Wave attack on gabions will lead to a complex flow over the gabions and through the gabions. During wave run-up the resulting forces by the waves will be directed opposite to the gravity forces. Therefore the run-up is less hazardous than the wave run-down.

Wave run-down, as it was already mentioned in Section 2, will lead to two important mechanisms:

The downward flowing water will exert a drag force on top of the gabions and the decreasing phreatic level will coincide with a downward flow gradient in the gabions.

- During maximum wave run-down there will be an incoming wave that a moment later will cause a wave impact. Just before impact there is a 'wall' of water giving a high pressure under the point of maximum run-down. Above the run-down point the surface of the gabions is almost dry and therefore there is a low pressure on the gabions. The interaction of high pressure and low pressure is shown in Figure 1.

A simple equilibrium of forces leads to the conclusion that the section from the run-down point to the phreatic line in the filter will slide down if:

- if there is insufficient support from gabions below this section
- if the downward forces exceed the friction forces: (roughly)  $f < 2 \cdot \tan \alpha$ , with:  $f$  = friction of gabion on subsoil;  $\alpha$  = slope angle.

From this criterion we see that a steep slope will easily lead to the exceeding of the friction forces, and furthermore a steep slope is shorter than a gentle slope and will give less support to the section that tends to slide down.

Hydrodynamic forces, such as wave attack and current, can lead to various damage mechanisms. The damage mechanisms fall into three categories:

1. Instability of the gabions
  - a) The gabions can slide downwards, compressing the down slope mattresses
  - b) The gabions can slide downwards, leading to upward buckling of the down slope mattresses
  - c) All gabions can slide downwards
  - d) Individual gabions can be lifted out due to uplift pressures
2. Instability of the subsoil
  - a) A local slip circle can occur, resulting in a S-profile
  - b) The subsoil can wash away through the gabions
3. Durability problems
  - a) Moving stones can cut through the mesh
  - b) Corrosion of the mesh
  - c) Rupture of the mesh by mechanical forces (vandalism, stranding of ship, etc.).

### 6.3 Stability of gabions under wave attack

An analytical approach of the development of the uplift pressure in the gabions can be obtained by applying the formulas for the uplift pressure under an ordinary pitched block revetment, with as leakage length:

$$\Lambda = 0.77 D .$$

With this relation the stability relations according to the analytical model are also applicable to gabions.

Substitution of values, which are reasonable for gabions, in the stability relations according to (CUR/CIRIA 1991) provides stability relations which indeed match the a line through the measured points.

After complicated calculations the uplift pressure in the gabions can be derived (Klein Breteler et al, 1998). The uplift pressure is dependent on the steepness and height of the pressure front on the gabions (which is dependent on the wave height, period and slope angle), the thickness of the gabions and the level of the freatic line in the gabions. It is not dependent on the permeability of the gabions, if the permeability is larger then the subsoil. The equilibrium of uplift forces and gravity forces leads to the following (approximate) design formula :

$$\frac{H_s}{\Delta D} = F \cdot \xi_{op}^{-2/3} \quad \text{with } 6 < F < 9 \text{ and slope of } 1:3 \text{ (tan}\alpha = 0.33) \quad (27a)$$

or, using Pilarczyk's equation (3c) with  $b=2/3$  and  $F = 9$  (see Figure 16):

$$\left( \frac{H_s}{\Delta D} \right)_{cr} = \frac{F \cos \alpha}{\xi_{op}^b} = \frac{9 \cos \alpha}{\xi_{op}^{2/3}} \quad (27b)$$

- with:
- $H_s$  = significant wave height of incoming waves at the toe of the structure (m)
  - $\Delta$  = relative density of the gabions (usually:  $\Delta \approx 1$ )
  - $D$  = thickness of the gabion (m)
  - $F$  = stability factor
  - $\xi_{op}$  = breaker parameter =  $\tan \alpha \sqrt{(H_s / (1.56 T_p^2))}$
  - $T_p$  = wave period at the peak of the spectrum (s)

It is not expected that instability will occur at once if the uplift pressure exceeds the gravity forces. On the other hand, the above result turns out to be in good agreement with the experimental results.

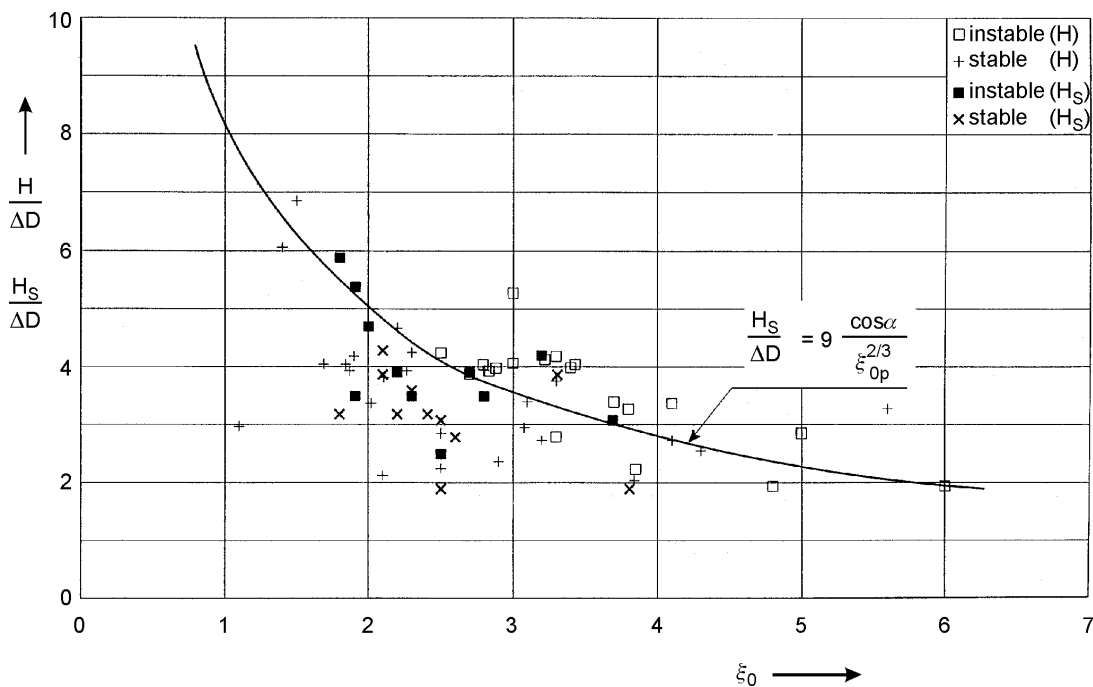

Figure 16: Summary of test results ((Ashe 1975) and (Brown 1979)) and design curves

The experimental verification of stability of gabions is rather limited. Small scale model tests have been performed by Brown (1979) and Ashe (1975), see Figure 16.

## 6.4 Motion of filling material

It is important to know if the filling material will start to move during frequent environmental conditions, because it can lead to rupture of the wire mesh. Furthermore the integrity of the system will be effected if large quantities of filling material is moved.

During wave attack the motion of the filling material usually only occurs if  $\xi_{op} < 3$  (plunging waves). Based on the Van der Meer's formula for the stability of loose rock (CUR/CIRIA, 1991) and the assumption that the filling of the gabion will be more stable then loose rock, the following criterion is derived (Van der Meer formula with permeability factor:  $0.1 < P < 0.2$ ; number of waves:  $2000 < N < 5000$ ; and damage level:  $3 < S < 6$ ):

$$\frac{H_s}{\Delta_f D_f} = \frac{F}{\sqrt{\xi_{op}}} \quad \text{with } 2 < F < 3 \quad (28)$$

with:

$H_s$  = significant wave height of incoming waves at the toe of the structure (m)

$\Delta_f$  = relative density of the grains in the gabions (usually:  $\Delta \approx 1.65$ )

$D_f$  = diameter of grains in the gabion (m)

$F$  = stability factor

$\xi_{op}$  = breaker parameter =  $\tan\alpha \sqrt{H_s / (1.56 T_p^2)}$

$T_p$  = wave period at the peak of the spectrum (s)

## 7 SCOUR AND TOE PROTECTION

Toe protection consists of the armouring of the beach or bottom surface in front of a structure which prevents it from scouring and undercutting by waves and currents. Factors that affect the severity of toe scour include wave breaking (when near the toe), wave run-up and backwash, wave reflection, and grain size distribution of the beach or bottom materials.

Toe stability is essential because failure of the toe will generally lead to failure throughout the entire structure. Toe scour is a complex process. Specific (generally valid) guidance for scour prediction and toe design based on either prototype or model results have not been developed as yet, but some general (indicative) guidelines for designing toe protection are given in SPM (1984) and CUR/RWS (1995).

The maximum scour force occurs where wave downrush on the structure face extends to the toe and/or the wave breaks near the toe (i.e. shallow water structure). These conditions may take place when the water depth at the toe is less than twice the height of the maximum expected unbroken wave that can exist at that water depth. The width of the apron for shallow water structures with a high reflection coefficient, which is generally true for slopes steeper than about 1 on 3, can be planned based on the structure slope and the expected scour depth. The maximum depth of a scour trough due to wave action below the natural bed is about equal to the maximum expected unbroken wave at the site. To protect the stability of the face, the toe soil must be kept in place beneath a surface defined by an extension of the face surface into the bottom to the maximum depth of scour. This can be accomplished by burying the toe, when construction conditions permit, thereby extending the face into an excavated trench the depth of the expected scour. Where an apron must be placed on the existing bottom, or can only be partially buried, its width should not be less than twice the wave height. Some solutions for toe protection can be found in Shore Protection Manual (SPM, 1984), CUR/CIRIA (1991) and PIANC (1987, 1992).

If the reflection coefficient is low (slopes milder than 1 on 3), and/or the water depth is more than twice the wave height, much of the wave force will be dissipated on the structure face and a smaller apron width may be adequate, but it must be at least equal to the wave height (minimum requirement). Since scour aprons generally are placed on very flat slopes, quarrystone of the size (diameter) equal to 1/2 or even 1/3 of the primary cover layer probably will be sufficient unless the apron is exposed above the water surface during wave action. Quarrystone of primary cover layer size may be extended over the toe apron if the stone will be exposed in the troughs of waves, especially breaking waves. The minimum thickness of cover layer over the toe apron should be two quarrystones. Quarrystone is the most favourable material for toe protection because of its flexibility. If a geotextile is used as a secondary layer it should be folded back at the end, and then buried in cover stone and sand to form a Dutch toe. It is recommended to provide an additional flexible edge (at least 1 m) consisting of loose material which may easily follow the scour at the toe. The size of toe protection against waves can also be roughly estimated

by using the common formulas on slope protection and schematizing the toe by mild slopes (i.e. 1 on 8 to 1 on 10). Some alternative designs of toe protection are shown in Figure 17.

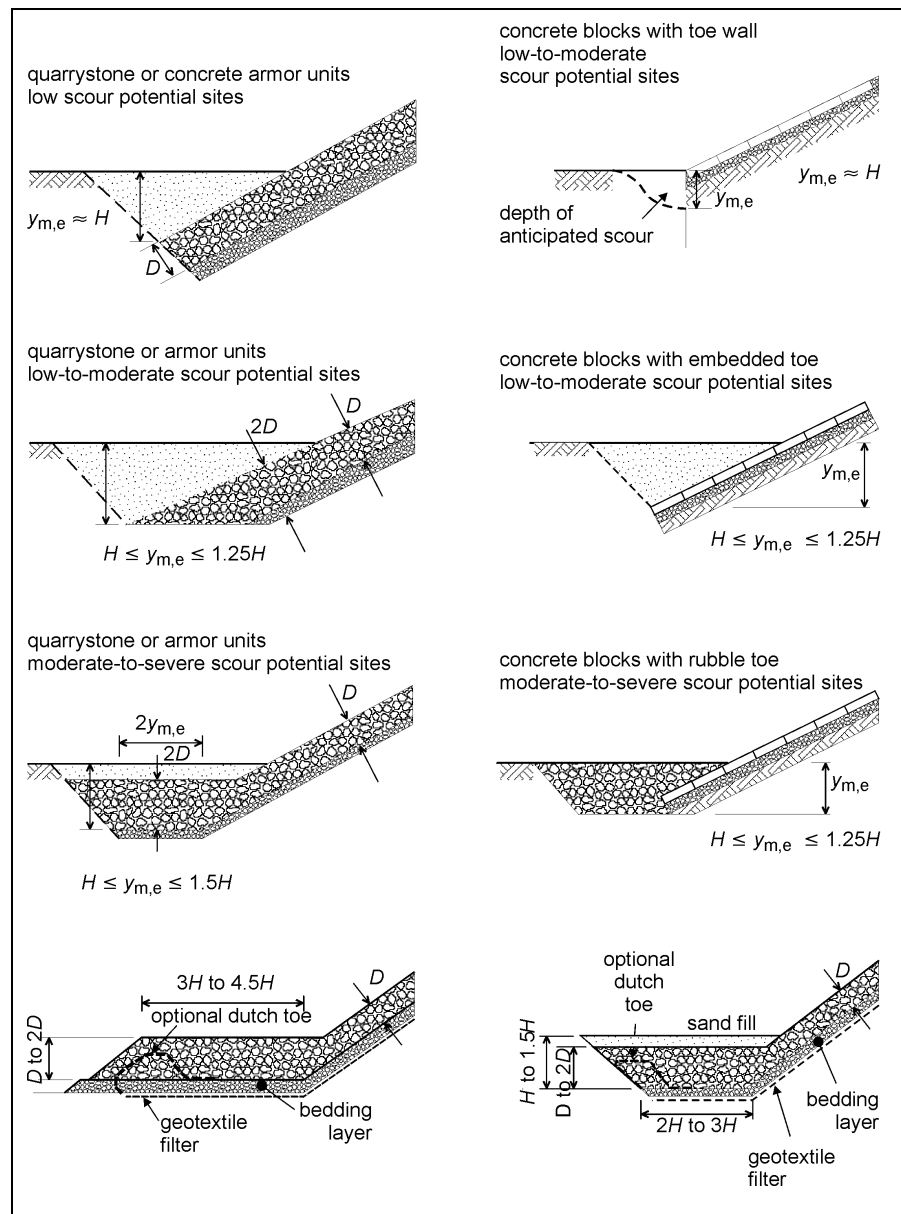

Figure 17 Alternative toe protections

Toe protection against currents may require smaller protective stone, but wider aprons. The necessary design data can be estimated from site hydrography and/or model studies. Special attention must be given to sections of the structure where scour is intensified; i.e. to the head, the areas of a section change in alignment, the channel sides of jetties, and the downdrift sides of groynes. Where waves and reasonable currents ( $>1$  m/s) occur together it is recommended to increase the cover size at least by a factor of 1.3.

Note that the conservatism of the apron design (width and size of cover units) depends on the accuracy of the methods used to predict the waves and current action and to predict the maximum depth of scour. For specific projects a detailed study of scour of the natural bottom and at nearby similar existing structures should be conducted at a planned site, and/or model studies should be considered before determining a final design. In all cases, experience and sound engineering judgement play an important role in applying these design rules.

## 8 PROTECTION AGAINST OVERTOPPING

If a structure (revetment) is overtopped, even by minor splash, the stability can be affected. Overtopping can: (a) erode the area above or behind the revetment, negating the structure's purpose; (b) remove soil supporting the top of the revetment, leading to the unravelling of the structure from the top down; and (c) increase the volume of water in the soil beneath the structure, contributing to drainage problems. The effects of overtopping can be limited by choosing a higher crest level or by armouring the bank above or behind the revetment with a splash apron. For a small amount of overtopping, a grassmat on clay can be adequate. The splash apron can be a filter blanket covered by a bedding layer and, if necessary to prevent scour due to splash, by riprap, concrete units or asphalt.

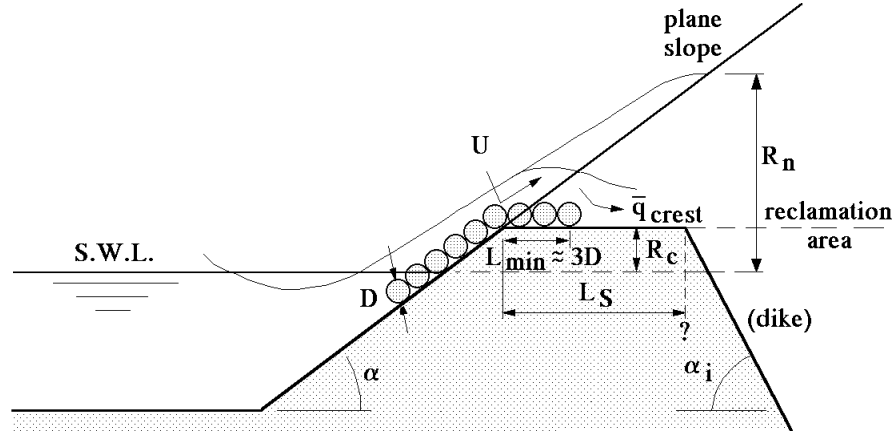

Figure 18 Definition of splash area

No definite method for designing against overtopping is known due to the lack of the proper method on estimating the hydraulic loading. Pilarczyk (1990) proposed the following, indicative way of design of the thickness of protection of the splash area (Figure 18):

$$\frac{H_s}{\Delta D_n} = \frac{1.5 \cos \alpha_i}{\Phi_T \xi^{2b} \left(1 - \frac{R_c}{R_n}\right)} \quad (29)$$

where:

$H_s$  = significant wave height,

$\xi$  = breaker index;  $\xi = \tan \alpha (H_s/L_o)^{-0.5}$ ,

$\alpha$  = slope angle,

$\alpha_i$  = angle of crest or inner slope,

$L_o$  = wave length,

$b$  = coefficient equal to 0.5 for smooth slopes and 0.25 for riprap,

$R_c$  = crest height above still water level,

$R_u$  = wave run-up on virtual slope with the same geometry, see Figure 18,

$D$  = thickness of protective unit ( $D = D_n$  for rock), and

$\Phi_T$  = total stability factor equal to 1.0 for rock, 0.5 for placed blocks and 0.4 for block mats.

The length of protection in the splash area, which is related to the energy decay, depends on the permeability of the splash area. However, it can be roughly assumed as equal to:

$$L_s = \frac{\psi}{5} T \sqrt{g(R_n - R_c)} \geq L_{\min} \quad (30)$$

with a practical minimum ( $L_{\min}$ ) equal at least to the total thickness of the revetment (including sublayers) as used on the slope.  $\psi$  is an engineering-judgement factor related to the local conditions (importance of structure),  $\psi \geq 1$ .

Stability of rockfill protection of the crest and rear slope of an overtopped or overflowed dam or dike can also be approached with the Knauss formula (Knauss, 1979). The advantage of this approach is that the overtopping discharge,  $q$ , can be used directly as an input parameter for calculation. Knauss analysed steep chute flow hydraulics (highly aerated/turbulent) for the assessment of stone stability in overflow

rockfill dams (impervious barrages with a rockfill spillway arrangement). This kind of flow seems to be rather similar to that during high overtopping. His (simplified) stability relationship can be re-written to the following form:

$$q = 0.625 \sqrt{g} (\Delta D_n)^{1.5} (1.9 + 0.8\phi_p - 3 \sin\alpha_i) \quad (31)$$

in which:

$q$  = maximum admissible discharge ( $\text{m}^3/\text{s}/\text{m}$ ),

$g$  = gravitational acceleration ( $9.81\text{m}/\text{s}^2$ ),

$D_n$  = equivalent stone diameter,  $D_n = (M_{50}/\rho_s)^{1/3}$ ,

$\Delta$  = relative density;  $\Delta = (\rho_s - \rho_w)/\rho_w$ ,

$\alpha_i$  = inner slope angle, and

$\phi_p$  = stone arrangement packing factor, ranging from 0.6 for natural dumped rockfill to 1.1 for optimal manually placed rock; it seems to be reasonable to assume  $\phi_p = 1.25$  for placed blocks.

*Note:* when using the Knauss formula the calculated critical (admissible) discharge should be identified with a momentary overtopping discharge per overtopping fraction of a characteristic wave, i.e. volume of water per characteristic wave divided by overtopping time per wave, roughly  $(0.3 \text{ to } 0.4)T$  ( $T$  = wave period), and not with the time-averaged discharge ( $q$ ).

## 9 JOINTS AND TRANSITIONS

Despite a well-designed protective system, the construction is only as strong as the weakest section. Therefore, special care is required when designing transitions. In general, slope protection of dike or seawall consists of a number of structural parts such as: toe protection, main protection in the area of heavy wave and current attack, upper slope protection (very often grass mat), berm for run-up reduction or as maintenance road. Different materials and different execution principles are usually applied for these specific parts. Very often a new slope protection has to be connected to an already existing protective construction which involves another protective system. To obtain a homogeneous strong protection, all parts of protective structures have to be taken under consideration.

Experience shows that erosion or damage often starts at joints and transitions. Therefore, important aspects of revetment constructions, which require special attention are the joints and the transitions; joints onto the same material and onto other revetment materials, and transitions onto other structures or revetment parts. A general design guideline is that transitions should be avoided as much as possible, especially in the area with maximum wave attack. If they are inevitable the discontinuities introduced should be minimized. This holds for differences in elastic and plastic behaviour and in the permeability or the sand tightness. Proper design and execution are essential in order to obtain satisfactory joints and transitions.

When these guidelines are not followed, the joints or transitions may influence loads in terms of forces due to differences in stiffness or settlement, migration of subsoil from one part to another (erosion), or strong pressure gradients due to a concentrated groundwater flow. However, it is difficult to formulate more detailed principles and/or solutions for joints and transitions. The best way is to combine the lessons from practice with some physical understanding of systems involved. Examples to illustrate the problem of transitions are given in Figure 19.

As a general principle one can state that the transition should be of a strength equal to or greater than the adjoining systems. Very often it needs a reinforcement in one of the following ways:

- a) increase the thickness of the cover layer at the transition,
- b) grout riprap or block cover layers with bitumen, and
- c) use concrete edge strips or boards to prevent damage progressing along the structure.

Top edge and flank protection are needed to limit the vulnerability of the revetment to erosion continuing around its ends. Extension of the revetment beyond the point of active erosion should be considered but is often not feasible. Care should therefore be taken that the discontinuity between the protected and unprotected areas is as small as possible (use a transition roughness) so as to prevent undermining. In some cases, open cell blocks or open block mats (eventually vegetated) can be used as transition (i.e. from hard protection into grass mat). The flank protection between the protected and unprotected areas usually needs a thickened or grouted cover layer, or a concrete edge strip with some flexible transition i.e. riprap.

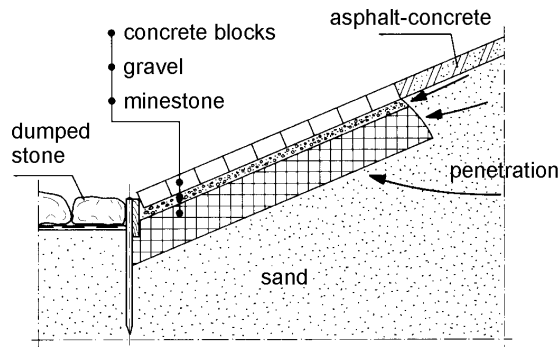

Penetration of sand into the mine-waste stone; geotextile between sand and minestone/gravel is necessary

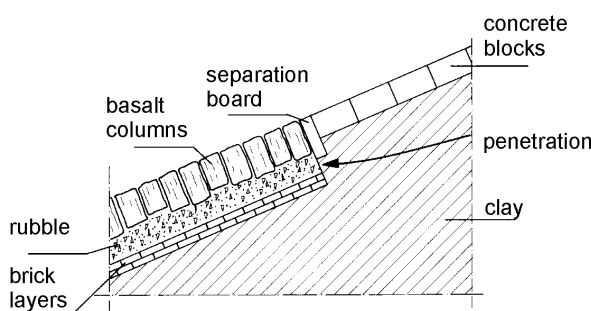
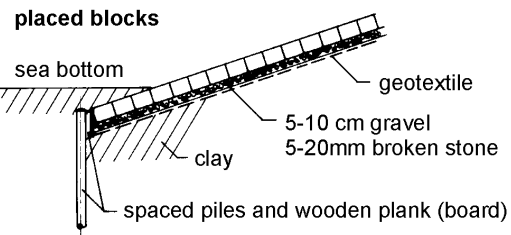
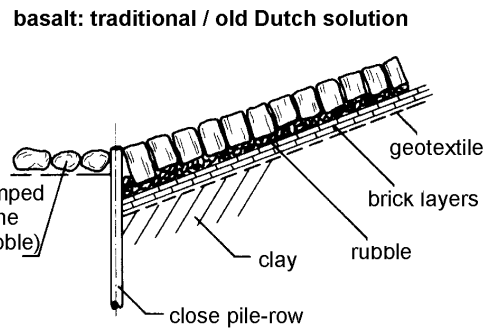

Transition from basalt columns to concrete blocks; separation board too short

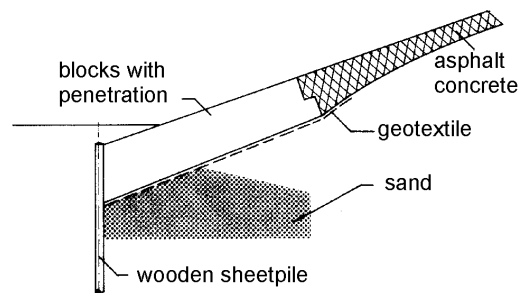

figure a) illustration of transition problems

figure b) examples of transitions (toe protection)

Figure 19 Transitions in revetments

## 10 GENERAL CONSTRUCTION (EXECUTION) ASPECTS

Revetments are constructed in a number of phases, for example:

- construction of the bank/dike body,
- placement of toe structure,
- placement of revetment sublayers (clay and/or filter layers),
- laying the blocks or mattress,
- anchoring the mattress and, possibly, applying the joint filler.

A well-compacted slope is important in order to produce a smooth surface and thus ensure that there is a good connection between the mattress and the subsurface. When laying mattresses on banks it is strongly recommended that they are laid on undisturbed ground and that areas excavated too deeply are carefully refilled. Before using a geotextile, the slope must be carefully inspected for any projections which could puncture the material. When laying a mattress on a geotextile care must be taken to ensure that extra pressures are not applied and that the geotextile is not pushed out of place. Geotextile sheets must be overlapped and/or stitched together with an overlap of at least 0.5 to 1.0 m to prevent subsoil being washed out. This is particularly important if the mattress is laid directly on sand or clay.

Block mattresses are laid using a crane and a balancing beam. The mattress must be in the correct position before it is uncoupled because it is difficult to pick up again and also time-consuming. Provided that part of the mattress can be laid above the water line, it can generally be laid very precisely and joints between adjacent mattresses can be limited to 1 to 2 cm. Laying a mattress completely under water is much more difficult. The spacing between the blocks of adjacent mattresses, nonetheless, should never be more than 3 cm.



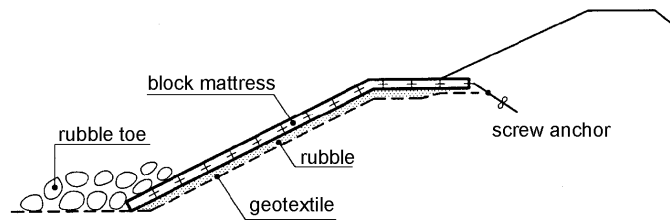
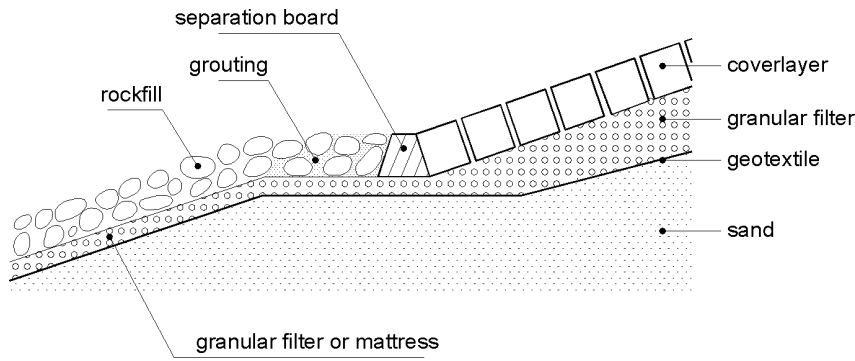

### Examples of toe protection

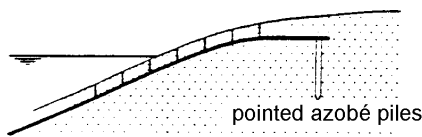

a) pointed azobé piles (wooden piles)

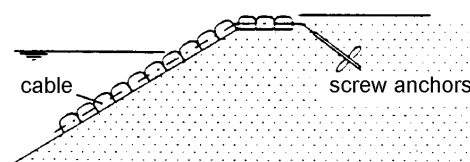

b) screw anchors

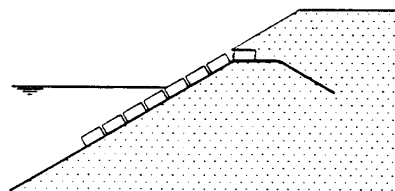

c) buried geotextile

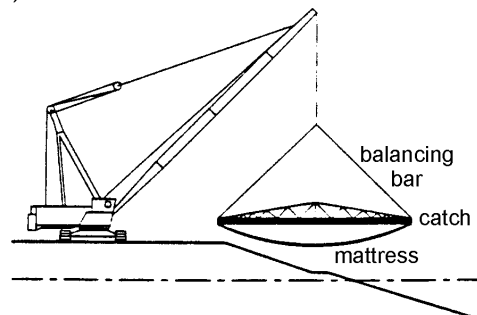

d) placing a mattress

### Placing a block mat (mattress) and some methods of anchoring

Figure 20 Construction aspects of revetments

Once in place, mattresses should be joined so that the edges cannot be lifted/turned up under the action of waves. Loose corners are particularly vulnerable. In addition, the top and bottom edges of the revetment should be anchored, as shown in Figure 20. In such a case, a toe structure is not needed to stop mattresses sliding.

More information on execution aspects of revetments can be found in (CUR/RWS, 1995, CUR/TAW, 1995, and Pilarczyk, 1998, 1999).

## 11 CONCLUSIONS

The newly derived design methods and stability criteria will be of help in preparing the preliminary alternative designs with various revetment systems. However, there are still many uncertainties in these design methods. Therefore, experimental verification and further improvement of design methods is necessary. Also more practical experience at various loading conditions is still needed.

## REFERENCES

- Ashe, G.W.T., 1975, Beach erosion study, gabion shore protection, *Hydraulics Laboratory*, Ottawa, Canada
- BAW, 1993, Code of Practice: Use of Geotextile Filters on Waterway, Bundesanstalt für Wasserbau, Karlsruhe, Germany.
- Brown, C., 1979, Some factors affecting the use of maccaferri gabions, *Water Research Lab.*, Australia, report 156.
- CFGG, 1986, Recommendations pour l'emploies geotextiles dans les systems de drainage et de filtration, Comite Francis des Geotextiles et Geomembranes, Paris, France.
- CUR, 1993, Filters in Hydraulic Engineering (in Dutch), Civil Engineering Research and Codes (CUR), Gouda, the Netherlands.
- DVWK, 1993, Guidelines for water managementno.306: application of geotextile in hydraulic engineering, German Association for Water Resources and Land Improvement (DVWK), Bonn, Germany.
- CUR/CIRIA, 1991, Manual on use of rock in coastal engineering, CUR/CIRIA report 154 Gouda, Netherlands.
- CUR/RWS, 1995, Manual on use of rock in hydraulic engineering, CUR report 169 ,Gouda, Netherlands.
- CUR/TAW 1995, Design Manual for Pitched Slope Protection, CUR report 155, A.A. Balkema (Publ.), Rotterdam.
- Flexible Armoured Revetments, 1984, Proceedings of the International Conference, Thomas Telford Ltd., london.
- FHWA, 1995, Geosynthetics Design and Construction Guidelines, Federal Highway Administration, FHWA-HI-95-038, Washington, D.C.
- Heerten, G., 1982, Dimensioning the Filtration Properties of Geotextiles Considering Long-term Conditions, Proc. 2nd Int. Conf. On Geotextiles, Las Vegas.
- Heerten, G., 1982, Geotextiles in Coastal Engineering, 25 years experience, Geotextiles and Geomembranes, Vol. 1, no. 2.
- Holtz, R.D., Christopher, B.R., and Berg, R.R., 1997, Geosynthetic Engineering, BiTech Publishers Ltb., Richmond, Canada.
- Klein Breteler, M. et al, 1998, Alternatieve open taludbekleding (Alternative open slope revetments, in Dutch), Delft Hydraulics, H1930
- Klein Breteler, M., K. W. Pilarczyk, T. Stoutjesdijk, 1998, Design of alternative revetments, Proceedings of the 26th International Conference on Coastal Engineering, Copenhagen, Denmark.
- Knauss, j., 1979, Computation of maximum discharge at overflow rock-fill dams, 13th Congress des Grand Barrages (ICOLD), New Delhi, Q50, R.9.
- Mlynarek, J., 1994, Evaluation of filter performance of geotextiles, prepared for Road and Hydraulic Engineering Division, Delft, the Netherlands.
- PIANC, 1984, Report of the International Commission For Improving The Design Of Fender Systems, Supplement to Bulletin No. 45, Brussels.
- PIANC, 1987, Guidelines for the design and construction of flexible revetments incorporating geotextiles for inland waterways, Report WG 4, PTC I, Supplement to Bulletin No. 57, Brussels, Belgium.
- PIANC Bulletin, 1987, Special issue on propeller jet action, erosion and stability criteria near the harbour quays, PIANC Bulletin no. 58, Brussels.
- PIANC, 1992, Guidelines for the design and construction of flexible revetments incorporating geotextiles in marine environment, Report WG 21, PTC II, Supplement to Bulletin No. 78/79, Brussels, Belgium.
- PIANC, 1997, Guidelines for the design of armoured slopes under piled quay walls, Supplement to Bulletin No. 96, brussels.
- Pilarczyk, K.W., (editor), 1990, Coastal Protection, Published by A.A. Balkema, Rotterdam.
- Pilarczyk, K.W., (editor), 1998, Dikes and revetments, Published by A.A Balkema, Rotterdam.
- Pilarczyk, K.W., 1999, Geosynthetics and Geosystems in Hydraulic and Coastal Engineering, Published by A.A. Balkema, Rotterdam; [balkema@balkema.nl](mailto:balkema@balkema.nl).
- EAU, 2000, Recommendations of the Committe for Waterfront Structures, German Society for Harbour Engineering, Ernst&Sohn, Berlin.
- RWS, 1987, The Closure of Tidal basins, Rijkswaterstaat, published by the Delft University Press, Delft.
- SPM, 1984, Shore Protection Manual, U.S. Army Corps of Engineers, Vicksburg.
- Van Santvoort, G., ed., 1994, Geotextiles and Geomembranes in Civil Engineering,, revised edition, A.A. Balkema, Rotterdam.

**KEY WORDS:**

Revetments

Stability

Wave attack

Current load

Block Mattresses

Gabions

Concrete Mattresses

Geotechnical Stability

Damage Mechanisms